

QUADRATURE ENCODER SMART INPUT MODULE

QUADRATURE ENCODER

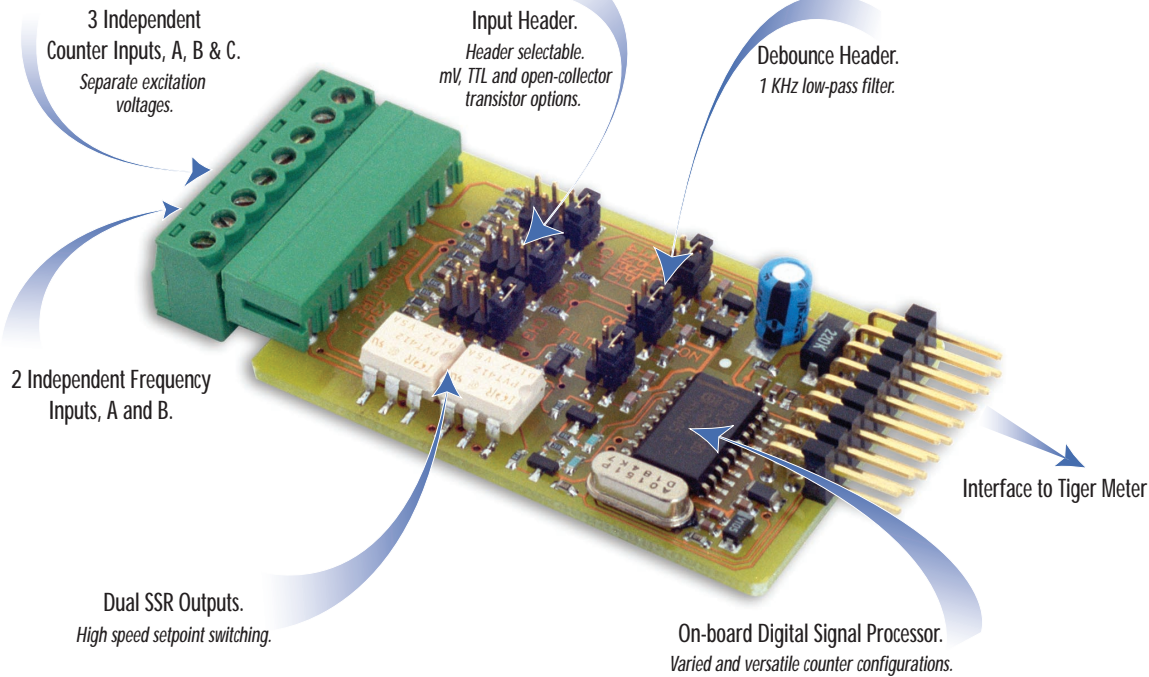

The total solution to incremental shaft encoder control

With this module you can not only sense position and direction of rotation, but the additional third channel can be used as the zero signal for precise determination of reference position. A variety of interface options and excitation voltages are provided to satisfy all user requirements including multiple counter inputs, a choice of two frequency channels and many interactive modes. When interfaced to the Tiger 320 Series operating system, these powerful software features provide the solution to all your counting needs in process control applications.

Input Module
Order Code Suffix

IC02 (No SSR)

IC03 (with 2 SSRs)



Hardware Module Specifications

Counter Inputs	3 independent hardware counters.
Input Header	Configured for mV, TTL, O.C (npn) or O.C (pnp) interface. Switching speed typically 20 kHz, operating mode dependent. (See Table 1).
Excitation Voltage	24 Vdc (50 mA maximum) available for all counter inputs.
SSRs	Dual, setpoint switching, solid-state relays. 17 Ω output impedance, \pm 400 V isolation, 140 mA maximum load current.
Debounce Header	Set to OFF position for high-speed encoding. Set to ON position for 1 kHz low-pass filter useful in contact push-button debounce inputs.

Software Module Features

Quadrature Mode	Choice of x1, x2 and x4 modes for increased resolution.
A, B Modes	A & B independent counter inputs arranged in various combinations.
C Mode	C counter control to capture, reset to predetermined counts, zero and/or restart A & B counters.
SSR Switching	Independent fast >1 ms setpoint switching of each SSR using counter selected from smart output register. Can be NO or NC relay outputs.
Frequency Option	100 kHz on A input, 500 kHz on B input.

Some Relevant Tiger 320 Series Operating System Features

Dual Rate (Frequency) On A and B.
Setpoint Timer Functions.
Setpoint Register Reset and Trigger Functions.
Macro Compiler for PLC Functions.

INPUTS
★ Smart UP/DOWN Counter
Multi Counter
Optional Dual High-speed S.S.R. Output

RPM, Pulse, Counter



The interface headers have been set to NPN input, the debounce headers are in the OFF position, and the encoder takes its excitation voltage directly from IC03.

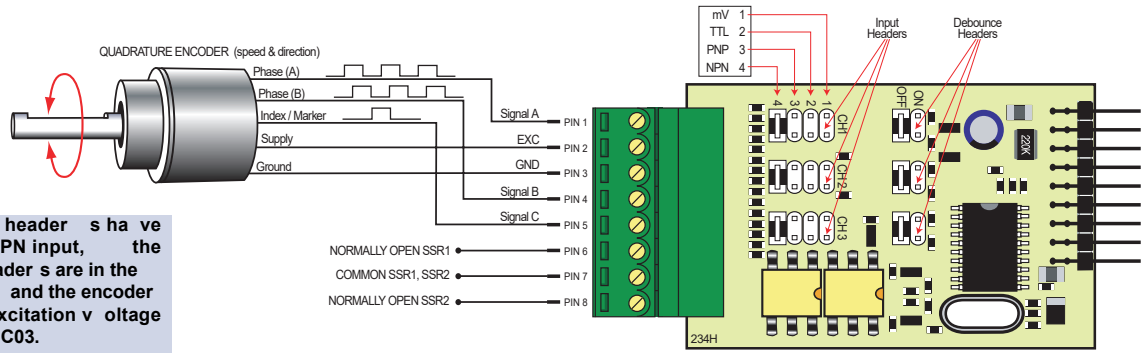

Figure 1 – IC03 Smart Input Module Wired to a Quadrature Encoder

Detailed Description

Smart Setup Registers

The meter has three smart setup registers to configure smart input modules. Smart input module IC02 requires only **smart register 1** to be set up, while IC03 requires **smart registers 1 and 2** to be set up. Figure 2 shows the functions of quadrature smart input modules IC02 and IC03 with input signals from a standard quadrature encoder.

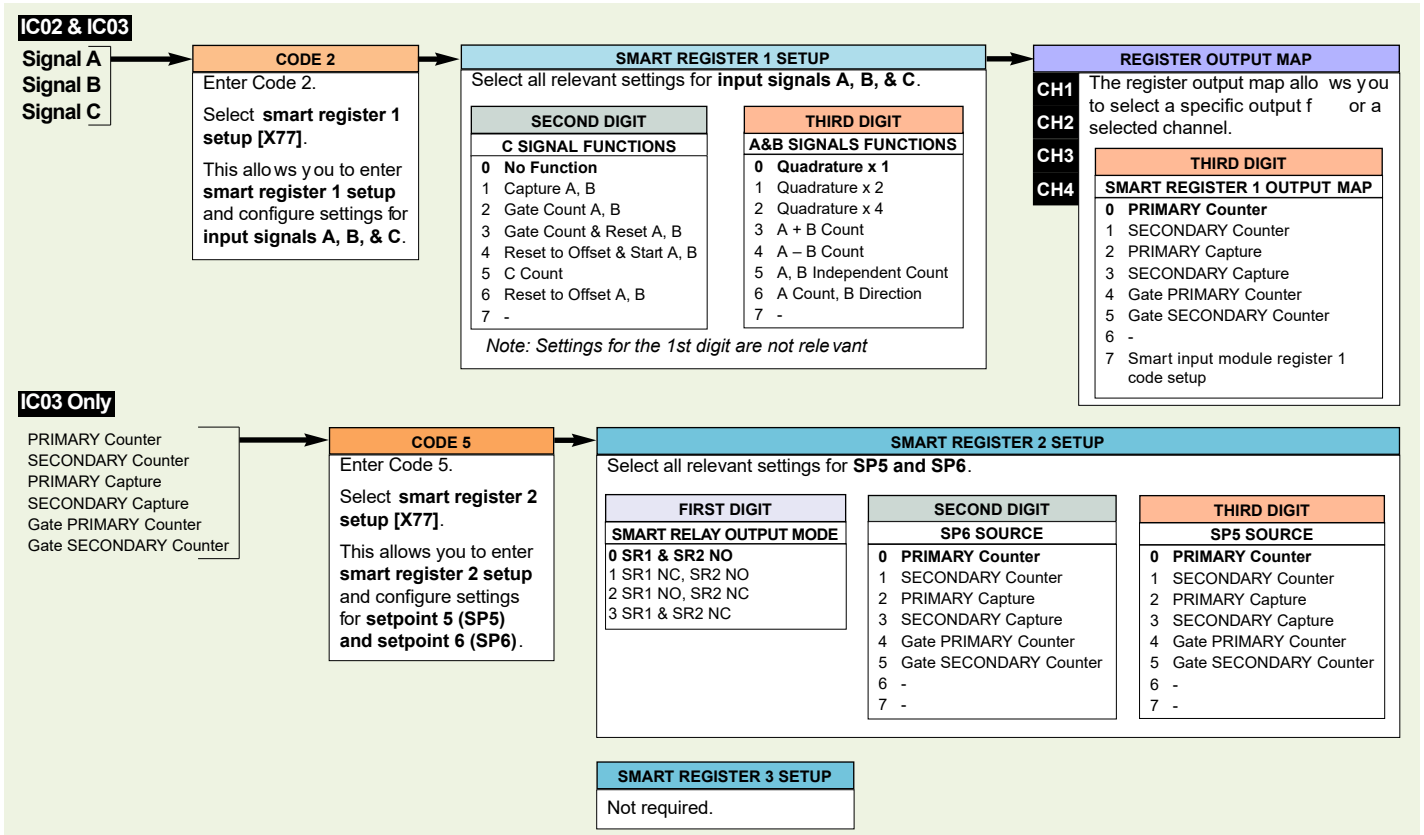

Figure 2 – IC02 & IC03 Quadrature Smart Setup Registers – Operational Flow Diagram

Smart Register 1

Smart register 1 allows you to select either the quadrature, combined, or independent counting mode for input signals A and B. Input signal C is the control mode for input signals A and B to capture, gate, zero, reset, or start the counters and is also selected through smart register 1. Input signal C can also be set as an independent counter without control over input signals A and B.

The resultant count produced by each mode is stored in the smart register output map in primary, secondary, capture or gate counters. Any of the counters can be transferred to Channel 1 via Code 2, to Channel 2 via Code 4, to Channel 3 via Code 5, and to Channel 4 via Code 6.

Smart Register 2 (IC03 Only)

Smart register 2 allows you to select the setpoint control settings of smart relay 1 (SR1) and smart relay 2 (SR2) using either the primary, secondary, capture, or gate counters of the smart register 2 output map. All other settings for SR1 are configured via setpoint 5 and for SR2 via setpoint 6 in the meter's setpoint programming mode.

Counter Functions

Counter inputs A, B, and C can be portrayed as a train of pulses having a **rising** edge (\nearrow or \uparrow) and **falling** edge (\searrow or \downarrow) between a low and high signal level. Depending on the counter function selected, these inputs may vary in phase to each other. In the case of a shaft encoder, the **A** signal lags the **B** signal by 90° and the primary counter decrements when the shaft is rotated clockwise. To change the direction of rotation to counterclockwise, reverse the A and B signal inputs at the connector (see Figure 1). The **C** signal occurs once per revolution.

See Figure 3.

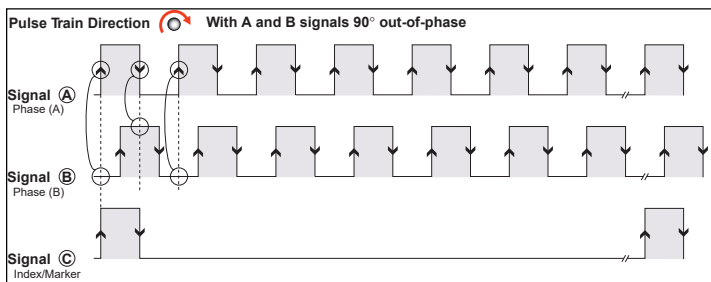

Figure 3 – Counter Input Signals

Counter Mode	Max. Frequency for A, B & C Inputs
Quadrature x1	20 kHz
Quadrature x2	20 kHz
Quadrature x4	10 kHz
A+B	10 kHz
A-B	10 kHz
A, B Independent	10 kHz
A Count, B Direction	10 kHz
Capture A, B	10 kHz
Gate Count A, B	10 kHz
Gate Count Reset A, B	10 kHz
Reset to Offset & Start A, B	10 kHz
C Count	38 kHz
Reset to Offset A, B	10 kHz

Table 1 lists the counter functions available and the maximum input frequency for each mode.

A and B Signal Functions

Quadrature Modes

The quadrature modes are shown for a shaft encoder as an example. Depending on the direction of rotation, the **A** signal leads or lags the **B** signal.

Using the same shaft encoder, the angular / linear resolution of the x1 Mode can be increased by 2 using the x2 Mode, or by 4 using the x4 Mode.

x1 Mode

This is the most commonly used counter function and operates as follows:

See Figures 4 and 5.

Direction of rotation: Clockwise

- The primary counter **decrements** on a **rising** edge (\nearrow) **A** signal when **B** is low.

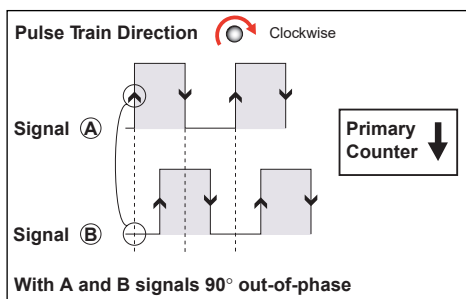

Figure 4 – x1 Mode: Primary Counter Decrements

Direction of rotation: Counterclockwise

- The primary counter **increments** on a **falling** edge (\searrow) **A** signal when **B** is low.

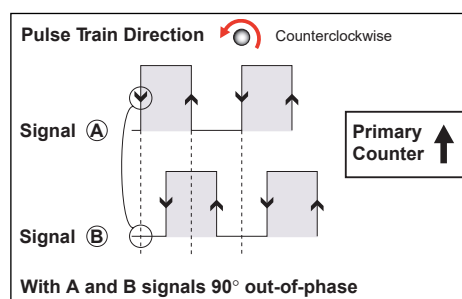

Figure 5 – x1 Mode: Primary Counter Increments

x2 Mode

The x2 mode operates as follows:

See Figures 6 and 7.

Direction of rotation: Clockwise

- The **primary** counter **decrements** on a **rising** edge (\nearrow) **A** signal when **B** is low.
- The **primary** counter **decrements** on a **falling** edge (\searrow) **A** signal when **B** is high.

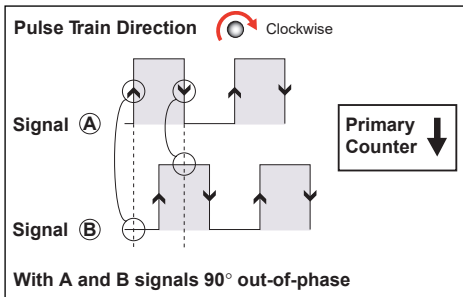

Figure 6 – x2 Mode: Primary Counter Decrements

x4 Mode

The x4 mode operates as follows:

See Figures 8 and 9.

Direction of rotation: Clockwise

- The **primary** counter **decrements** on a **rising** edge (\nearrow) **A** signal when **B** is low.
- The **primary** counter **decrements** on a **rising** edge (\nearrow) **B** signal when **A** is high.
- The **primary** counter **decrements** on a **falling** edge (\searrow) **A** signal when **B** is high.
- The **primary** counter **decrements** on a **falling** edge (\searrow) **B** signal when **A** is low.

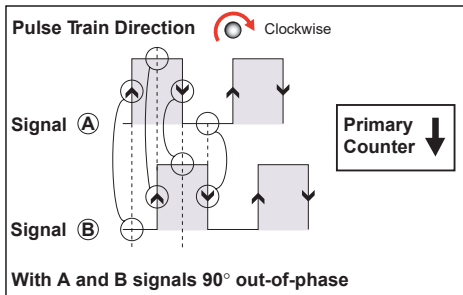

Figure 8 – x4 Mode: Primary Counter Decrements

A+B Signal Count Mode (Anticoincident)

There is no fixed relationship between A and B. Signal A increments the primary counter on every rising edge. Signal B increments the primary counter on every rising edge.

The A+B signal count mode operates as follows:

See Figure 10.

- The **primary** counter **increments** on a **rising** edge (\nearrow OR \nearrow) **A** signal.
- The **primary** counter **increments** on a **rising** edge (\nearrow OR \nearrow) **B** signal.

Application:

You may have two production lines in a factory with a sensor on each line. By adding the totals of each counter you can determine the total output of the factory.

Direction of rotation: Counterclockwise

- The **primary** counter **increments** on a **rising** edge (\nearrow) **A** signal when **B** is high.
- The **primary** counter **increments** on a **falling** edge (\searrow) **A** signal when **B** is low.

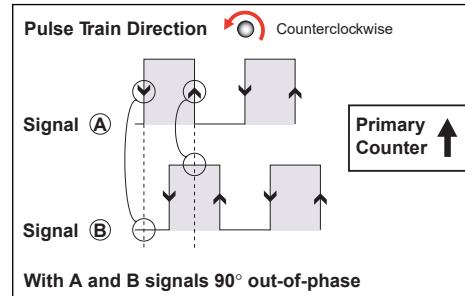

Figure 7 – x2 Mode: Primary Counter Increments

Direction of rotation: Counterclockwise

- The **primary** counter **increments** on a **rising** edge (\nearrow) **A** signal when **B** is high.
- The **primary** counter **increments** on a **rising** edge (\nearrow) **B** signal when **A** is low.
- The **primary** counter **increments** on a **falling** edge (\searrow) **A** signal when **B** is low.
- The **primary** counter **increments** on a **falling** edge (\searrow) **B** signal when **A** is high.

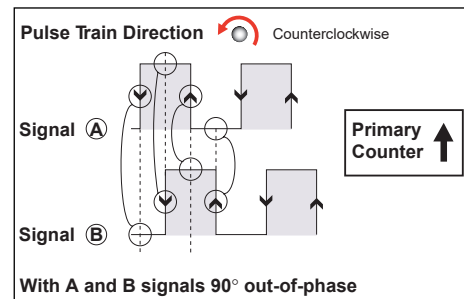

Figure 9 – x4 Mode: Primary Counter Increments

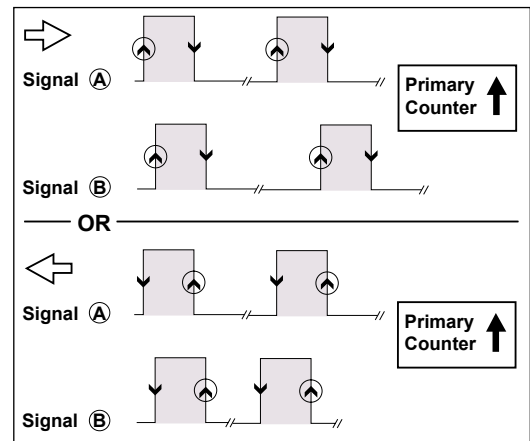

Figure 10 – A+B Signal Count Mode: Primary Counter Increments

A–B Signal Count Mode (Anticoincident)

The A and B signals are linked in a phase relationship. Signal A increments the primary counter on every rising edge, while signal B decrements the primary counter on every rising edge.

The A–B signal count mode operates as follows:

See Figure 11.

- The **primary** counter **increments** on a **rising** edge (↗ or ↘) **A** signal.
- The **primary** counter **decrements** on a **rising** edge (↗ or ↘) **B** signal.

Application:

This mode is useful when the difference between two counts is required. For example, a carpark building where the A signal represents an incoming car and the B signal represents an outgoing car. A minus B lets you know how many cars are in the building at any one time.

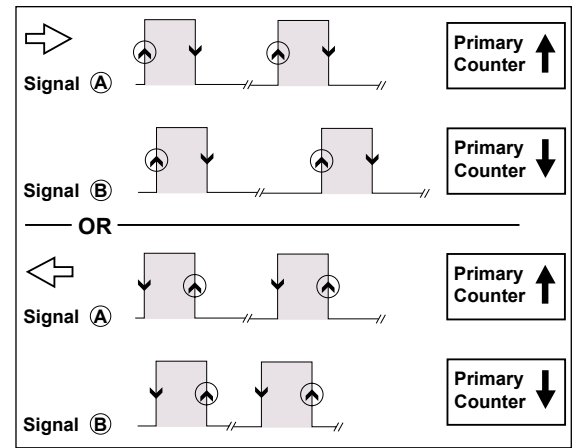

Figure 11 – A–B Signal Count Mode: Primary Counter Increments/Decrements

A&B Independent Mode (Anticoincident)

There is no fixed relationship between signals A and B. Signal A increments the primary counter on every rising edge. Signal B increments the secondary counter on every rising edge.

The A&B independent mode operates as follows:

See Figure 12.

- The **primary** counter **increments** on a **rising** edge (↗ or ↘) **A** signal.
- The **secondary** counter **increments** on a **rising** edge (↗ or ↘) **B** signal.

Application:

This mode is useful for dual counting systems.

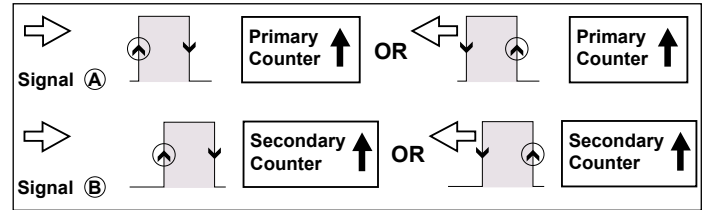

Figure 12 – A&B Independent Mode: Primary Counter Increments, Secondary Counter Increments

A Count, B Direction Mode

The A and B signals are linked in a phase relationship. Signal A increments the primary counter on every rising edge when signal B is low. Signal A also decrements the primary counter on every rising edge when signal B is high.

The A count, B direction mode operates as follows:

See Figures 13 and 14.

- The **primary** counter **increments** on a **rising** edge (↗ or ↘) **A** signal when **B** is low.

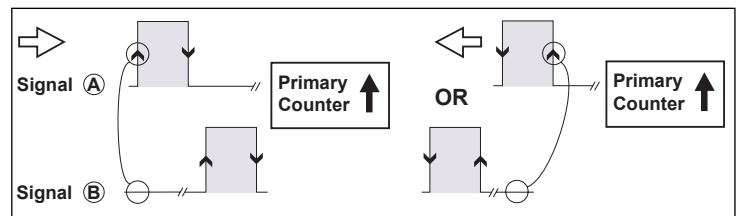

Figure 13 – A Count, B Direction Mode: Primary Counter Increments

- The **primary** counter **decrements** on a **rising** edge (↗ or ↘) **A** signal when **B** is high.

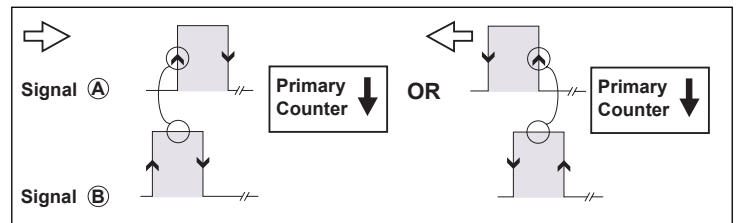

Figure 14 – A Count, B Direction Mode: Primary Counter Decrements

Application:

Some positional encoders have this type of output instead of a quadrature output.

C Signal Functions

C signal functions operate with the A and B signal functions and influence the primary and secondary gate and capture counters.

Capture A, B Mode

The capture A, B mode provides a snapshot of the primary and secondary counters. It is a straight transfer of the values from the primary and secondary counters to primary and secondary capture.

See Figure 15.



Note:

The primary and secondary counters are not affected by the operation and no counts are lost.

- The **primary counter** value is loaded into **primary capture** on a **falling edge** (Ψ) **C** signal.
- The **secondary counter** value is loaded into **secondary capture** on a **falling edge** (Ψ) **C** signal.

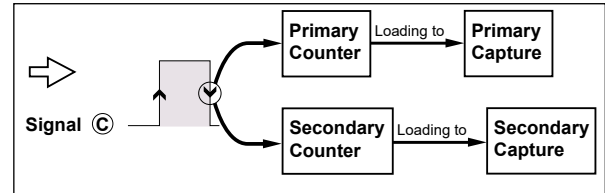

Figure 15 – Capture A, B Mode

Application:

This mode is useful to capture positional information in relation to an external event. To track if any errors occur, the positional information could be used as a reference that the encoder can be compared against.

Gate Count A, B

In this mode the primary and secondary gate counters are updated with the number of pulses that occur in the primary (A signal) and secondary (B signal) counters respectively between consecutive falling edge C signal pulses. The primary and secondary counters are not reset and continue to count after each update of the gate counters. The gate count A, B mode operates as follows:

See Figure 16.

- The value in the **primary counter** on the previous **falling edge** (Ψ) **C** signal is subtracted from the value in the **primary counter** on the most recent **falling edge** (Ψ) **C** signal and loaded into the **primary gate counter**. The **primary counter** continues to count up and is not reset after each event.
- The value in the **secondary counter** on the previous **falling edge** (Ψ) **C** signal is subtracted from the value in the **secondary counter** on the most recent **falling edge** (Ψ) **C** signal and loaded into the **secondary gate counter**. The **secondary counter** continues to count up and is not reset after each event.



Note:

The gate secondary counter is only updated in the A & B independent mode.

Application:

This mode is useful to capture rate information in relation to an external event. For example, you may want to know how much product was produced per shift. At the start of the shift, the operator could set a switch and reset it at the end of the shift. The resultant gate counter would let you know how much was produced during that shift.

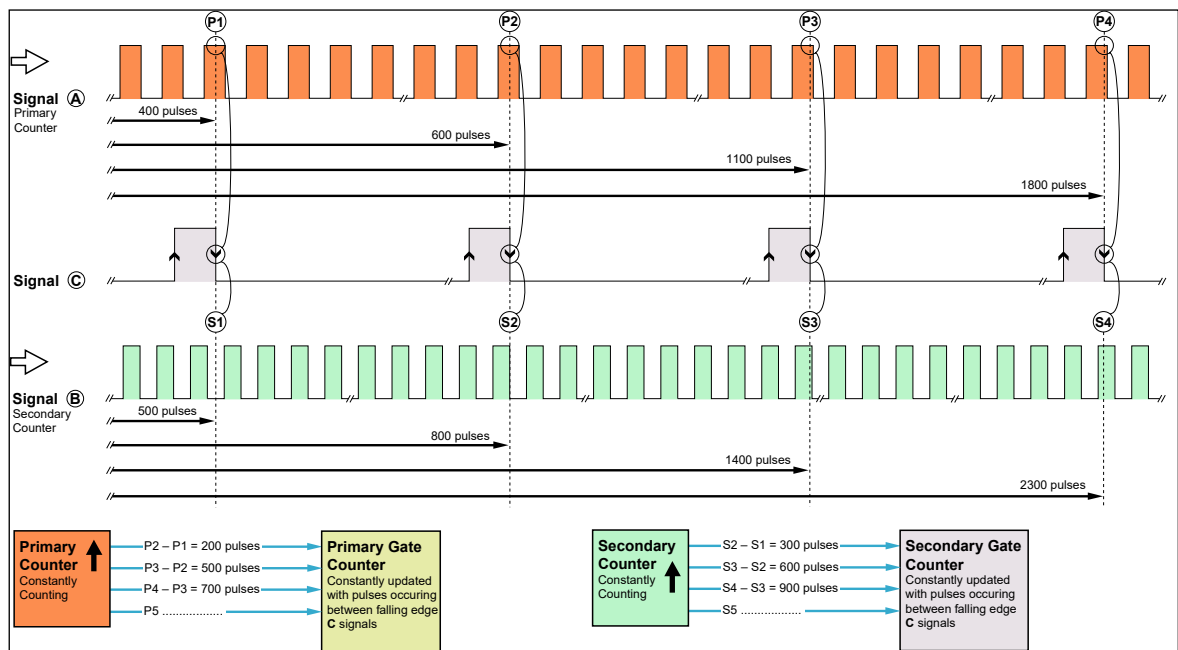

Figure 16 – Snapshot of Gate Count A, B Mode: Primary Counter

Gate Count & Reset A, B Mode

In this mode the primary and secondary gate counters are again updated with the number of pulses that occur in the primary (A signal) and secondary (B signal) counters respectively between consecutive falling edge C signal pulses. But, in this case, the primary and secondary counters are reset after each update of the gate counters. The gate count & reset mode operates as follows:

See Figure 17.

- The value in the **primary** counter on the previous falling edge (\downarrow) C signal is subtracted from the value in the **primary** counter on the most recent falling edge (\downarrow) C signal and loaded into the **primary gate** counter. The **primary** counter stops counting after each falling edge C signal event and is reset to 0.
- The value in the **secondary** counter on the previous falling edge (\downarrow) C signal is subtracted from the value in the **secondary** counter on the most recent falling edge (\downarrow) C signal and loaded into the **secondary gate** counter. The **secondary** counter stops counting after each falling edge C signal event and is reset to 0.

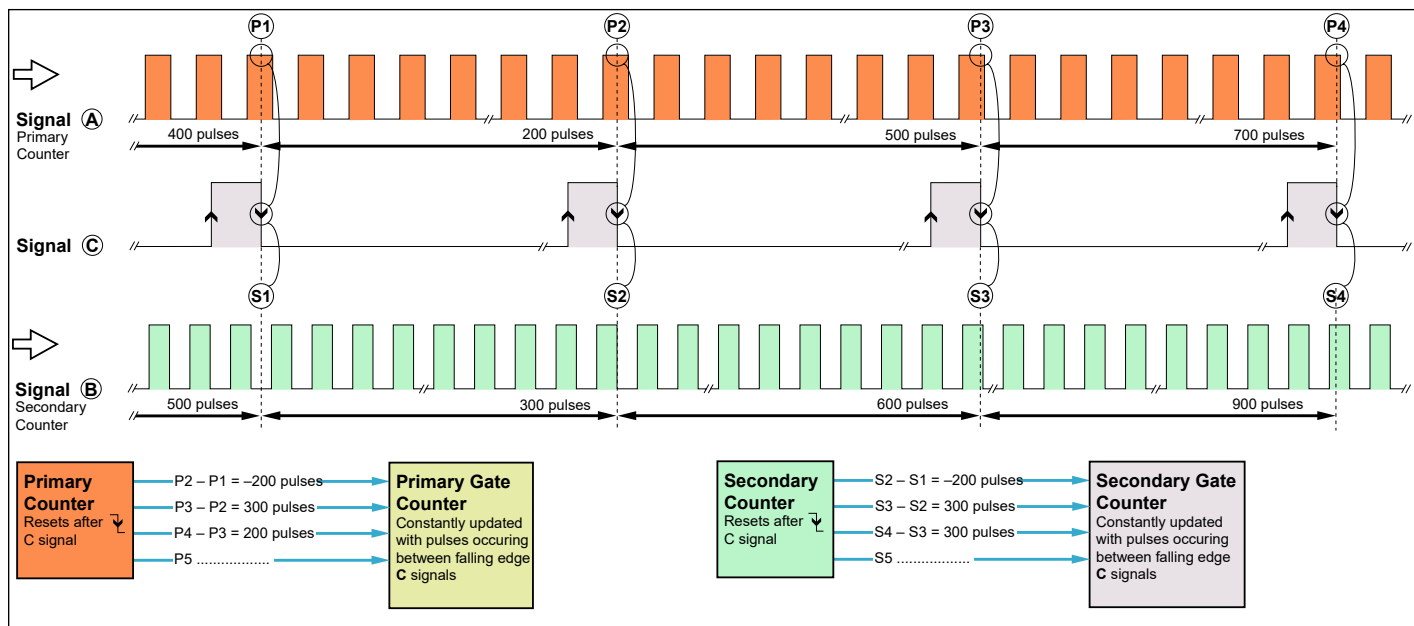

Figure 17 – Snapshot of Gate Count & Reset Mode

Reset to Offset & Start A, B Mode

In this mode the primary and secondary counters are reset to the value stored in the meter's primary and secondary reset offset registers (registers 121 and 122 respectively). Primary and secondary counters continue counting after being reset to the reset offset values.

The reset to offset & start A, B mode operates as follows:

See Figure 18.

- The primary and secondary counters begin counting on a **rising** edge (\uparrow) C signal.
- On a **falling** edge (\downarrow) C signal the **primary** counter is reset to the value stored in the **primary reset offset register (121)**, and the secondary counter reset to the value stored in the **secondary reset offset register (122)**.

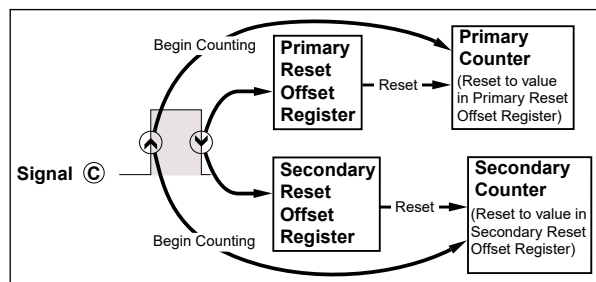

Figure 18 – Reset to Offset & Start Mode

The default setting of the primary and secondary reset offset registers is 0. To change the value stored in these registers:

- Connect the meter to a PC running a terminal program.
- Start the terminal program.
- Access register 121 and change the offset to the required value.
- Access register 122 and change the offset to the required value.

See Registers Supplement (NZ209), Registers 121 and 122 – Reset Offset Registers, for a detailed description of the reset offset registers.

Application:

This mode is useful for when an external reset is required. For example, A pushbutton on the C input can be used to reset to 0, or forward the counter to a known count. The counter starts again when the button is released.

C Count Mode

In this mode the **primary** counter **increments** on a **rising edge** (↑) C signal only.

See Figure 19.

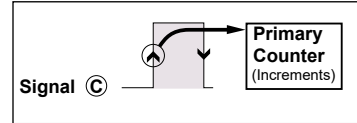

Figure 19 – C Count Mode

Application:

This mode is useful for multi-input systems.

Reset to Offset A, B Mode

In this mode the primary and secondary counters are also reset to the value stored in the meter's primary and secondary reset offset registers (registers 121 and 122 respectively). But, in this mode, the primary and secondary counters continue counting after being reset to the reset offset values.

See Figure 20.

The reset to offset A, B mode operates as follows:

- On a **falling edge** (↓) C signal the **primary** counter is reset to the value stored in the **primary reset offset register (121)**, and the secondary counter reset to the value stored in the **secondary reset offset register (122)**.
- The primary and secondary counters continue to count on being reset.

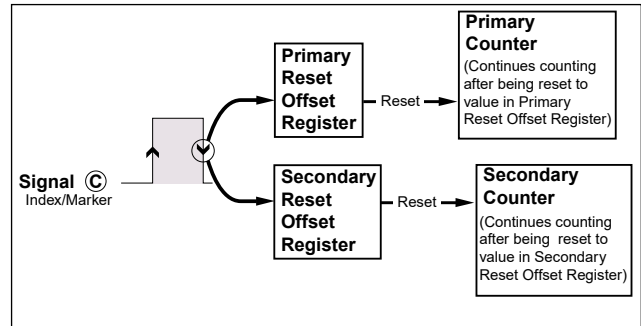

Figure 20 – Reset to Offset A, B Mode

Application:

This mode is useful for setting a position to a known reference position. For example, a microswitch can be positioned at 'home' and used as an input to C on a milling table. Now every time the 'home' position is encountered, the counter is set to a known position.

Programming Quick Start Guide

Programming Procedures

1 Press the [P] and [↑] buttons at the same time to enter the main programming mode.

2 Press the [P] button three times to enter Code 2. Set Code 2 to [X77].

Cod_2 X77

This setting enters the **smart register 1** code setup menu.



Note the register map is different for each smart input module type.

FIRST DIGIT
TIGER PROCESSING RATE
0 10 Hz
1 100 Hz
2 1000 Hz
3 10000 Hz

SECOND DIGIT
MEASUREMENT TASK
0 Voltage, Current
1 TC (3rd digit selects type of TC)
2 RTD 3-wire (3rd digit selects type of RTD)
3 RTD 2- or 4-wire (3rd digit selects type of RTD)
4 Frequency
5 Period
6 Counter
7 Smart Input Module

THIRD DIGIT
SMART REGISTER 1 OUTPUT MAP
0 PRIMARY Counter
1 SECONDARY Counter
2 PRIMARY Capture
3 SECONDARY Capture
4 Gate PRIMARY Counter
5 Gate SECONDARY Counter
6 -
7 Smart input module register 1 code setup

3 Press the [P] button.

SP7E 1 000

This menu provides settings unique to **smart register 1** of the IC02/IC03 input module.

FIRST DIGIT
Not Relevant

SECOND DIGIT
C SIGNALS FUNCTIONS
0 No Function
1 Capture A, B
2 Gate Count A, B
3 Gate Count & Reset A, B
4 Reset to Offset & Start A, B
5 C Count
6 Reset to Offset A, B
7 -

THIRD DIGIT
A&B SIGNALS FUNCTIONS
0 Quadrature x 1
1 Quadrature x 2
2 Quadrature x 4
3 A + B Count
4 A - B Count
5 A, B Independent Count
6 A Count, B Direction
7 -

4 Using the [↓] [↑] buttons, select the function f or the A & B inputs and the function for the C input.



Note, see Detailed Description on Page 3 f or a description of A, B, and C counter functions.

5 Press the **P** button. The display returns to [Cod_2] [X77]. Cod_2 X77

6 Using the **↓** button, reset the 3rd digit to zero [X70] to leave the smart register 1 menu. 07X
 Note, leaving the 3rd digit as 7 means the display constantly cycles between [Cod_2] and [SMt1].

7 Press the **P** button 3 times to enter Code 5. Set Code 5 to [X77].

Cod_5 X77

FIRST DIGIT
TIGER PROCESSING RATE
0 Direct Display of Input (no processing)
1 Square Root of Channel 3
2 Inverse of Channel 3
3 Meters with 4 kB memory NO Linearization
Meters with 32 kB memory 32-point Linearization of CH3 using Table 3
<i>Note: All linearization tables are set up in the Calibration Mode [24X].</i>

SECOND DIGIT
MEASUREMENT TASK
0 No function
1 Voltage, current
2 TC
3 RTD
4 Real-time clock & timer
5 -
6 -
7 Smart input module

THIRD DIGIT
SMART REGISTER 2 OUTPUT MAP
0 PRIMARY Counter
1 SECONDARY Counter
2 PRIMARY Capture
3 SECONDARY Capture
4 Gate PRIMARY Counter
5 Gate SECONDARY Counter
6 -
7 Smart input module register 2 code setup

8 Press the **P** button.
 This setting enters the **smart register 2** code setup menu.

57762 000

This menu provides settings unique to **smart register 2** of the IC02/IC03 input module.

FIRST DIGIT
SMART RELAY OUTPUT MODE
0 SR1 & SR2 NO
1 SR1 NC, SR2 NO
2 SR1 NO, SR2 NC
3 SR1 & SR2 NC

SECOND DIGIT
SP6 SOURCE
0 PRIMARY Counter
1 SECONDARY Counter
2 PRIMARY Capture
3 SECONDARY Capture
4 Gate PRIMARY Counter
5 Gate SECONDARY Counter
6 -
7 -

THIRD DIGIT
SP5 SOURCE
0 PRIMARY Counter
1 SECONDARY Counter
2 PRIMARY Capture
3 SECONDARY Capture
4 Gate PRIMARY Counter
5 Gate SECONDARY Counter
6 -
7 -



Note the register map is different for each smart input module type.

9 Select the setpoint source for switching from the smart output registers for SP5 in the 3rd digit and SP6 in the 2nd digit, and the operating mode of the solid state relays SR1 and SR2 in the 1st digit.

10 Press the **P** button to save the settings.

The display toggles between [Cod_5] and [X77]. Cod_5 X77

11 Using the **↓** button, reset the 3rd digit to 0 to leave the smart register 2 menu.

12 Press the **P** and **↑** button at the same time to return to the operational display.

Select a Channel Select the output register for the required channels

13 Press the **P** and **↑** button at the same time again to re-enter the main programming mode.

14 Press the **P** button three times to enter Code 2.

15 Set Code 2 to [X7X]. Select the required processing rate for **CH1** in the 1st digit and the required register map settings in the 3rd digit.

CH1 Cod_2 X7X

FIRST DIGIT
TIGER PROCESSING RATE
0 10 Hz
1 10 Hz
2 100 Hz
3 100 Hz

THIRD DIGIT
SMART REGISTER OUTPUT MAP
0 PRIMARY Counter
1 SECONDARY Counter
2 PRIMARY Capture
3 SECONDARY Capture
4 Gate PRIMARY Counter
5 Gate SECONDARY Counter
6 -
7 Smart input module register code setup



Note the register map is different for each smart input module type.

16 Set Code 4 to [0X0]. Select the required register map settings for CH2 in the 2nd digit.

CH2 Cod_4 0X0

FIRST DIGIT	SECOND DIGIT	
MEASUREMENT TASK	FOR VOLTAGE & CURRENT	<i>*Note: The logic for CH2 is not the same as CH1, CH3, or CH4. The 1st and 3rd digits must both be set to 0. Selecting 040 to 070 in the 2nd digit of Code 4 directly selects one of the following settings in the register output map (3rd digit):</i>
0 Voltage, Current	0 Channel 2 Disabled	
1 TC (type as per 2nd digit)	1 Direct (no post processing)	
2 RTD (type as per 2nd digit)	2 Square Root of Channel 2	
3 Second Digital Input Channel (type as per 2nd digit)	3 Inverse of Channel 2	
	4 Output Register 1 (smart module)*	
	5 Output Register 2 (smart module)*	
	6 Output Register 3 (smart module)*	
	7 Output Register 4 (smart module)*	
	2nd Digit	Register Output Map
	4 selects	0 PRIMARY Counter
	5 selects	1 SECONDARY Counter
	6 selects	2 PRIMARY Capture
	7 selects	3 SECONDARY Capture

17 If required enter Code 5 and select the required register map settings for CH3 in the 3rd digit.

CH3 Cod_5 X7X

FIRST DIGIT	THIRD DIGIT
CH3 POST PROCESSING	SMART REGISTER 1 OUTPUT MAP
0 Direct Display of Input (no processing)	0 PRIMARY Counter
1 Square Root of Channel 3	1 SECONDARY Counter
2 Inverse of Channel 3	2 PRIMARY Capture
3 Meters with 4 kB memory	3 SECONDARY Capture
NO Linearization	4 Gate PRIMARY Counter
Meters with 32 kB memory	5 Gate SECONDARY Counter
32-point Linearization of CH3 using Table 3	6 -
<i>Note: All linearization tables are set up in the Calibration Mode [24X].</i>	7 Smart input module register 1 code setup



Note the register map is different for each smart input module type.

18 If required enter Code 6 and select the required register map settings for CH4 in the 3rd digit.

CH4 Cod_6 X7X

FIRST DIGIT
CH4 POST PROCESSING
0 Direct Display of Input (no processing)
1 Square Root of Channel 4
2 Inverse of Channel 4
3 Meters with 4 kB memory
NO Linearization
Meters with 32 kB memory
32-point Linearization of CH4 using Table 4
<i>Note: All linearization tables are set up in the Calibration Mode [24X].</i>



Note, to measure frequency on A and B inputs select the appropriate options in Code 2 and Code 4 respectively.

Press the **P** button to save the settings.

19 Press the **P** and **↑** buttons at the same time to return to the operational display.

Customer Configuration Settings:

1st Digit 2nd Digit 3rd Digit
5P7E1

1st Digit 2nd Digit 3rd Digit
5P7E2

CH1 Cod_2 7

CH2 Cod_4 0 0

CH3 Cod_5 7

CH4 Cod_6 7

Our customer operates an automatic cut-to-length guillotine. A Texmate 320 Series programmable meter controller has been installed and programmed to measure length from an encoder input. Setpoint 1 is programmed to operate at the required cut-off length. A clutch and a clamp operate to stop the metal feed motor.

After a programmed OFF-time, (to enable the guillotine to complete its cut cycle) the displayed length is reset to 0. The clamp releases, the clutch engages, and the metal commences feeding, repeating the process. At each cut-off, 1 is added to a totalizer. (Viewed by pressing the UP button.)

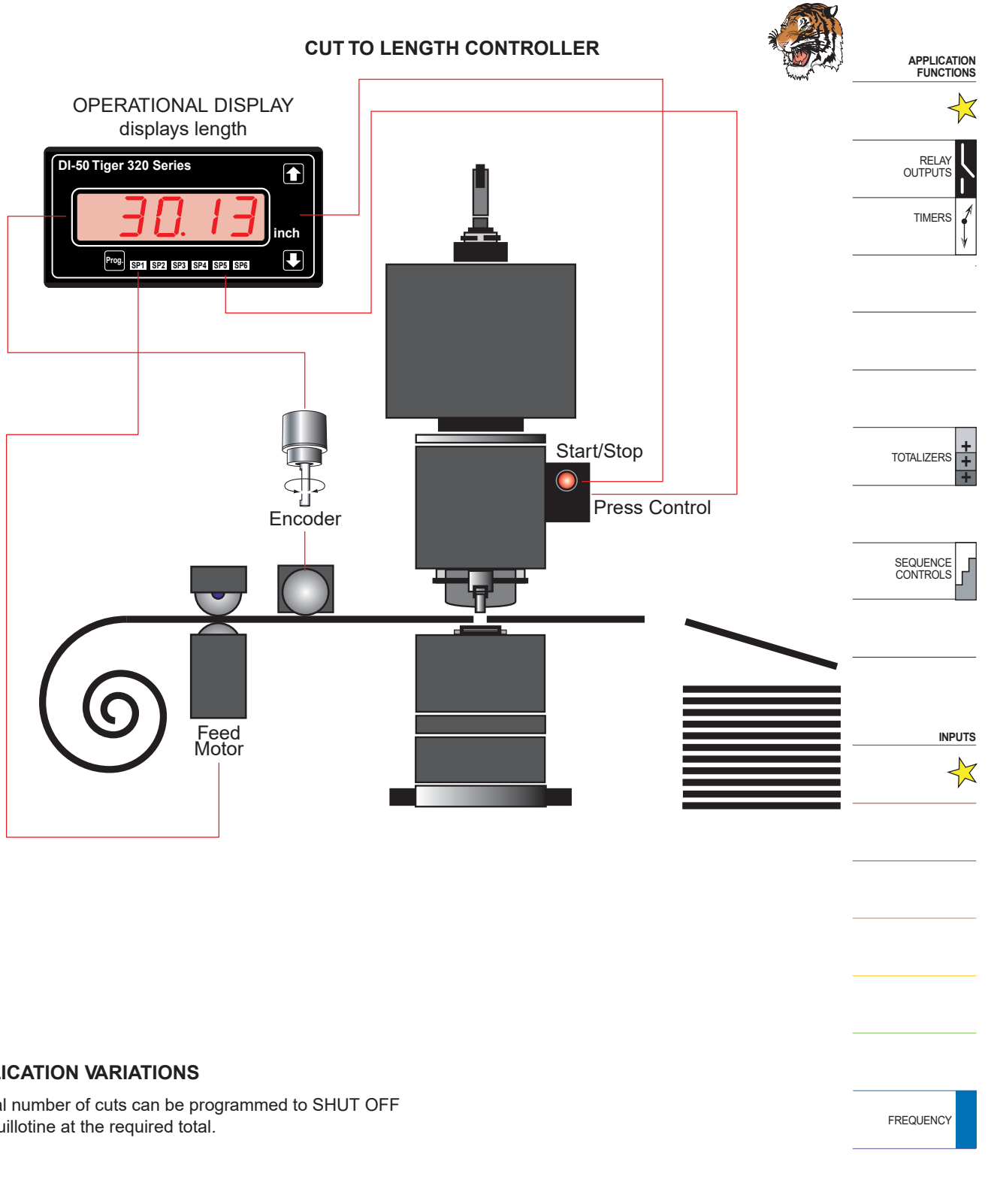

APPLICATION VARIATIONS

- A total number of cuts can be programmed to SHUT OFF the guillotine at the required total.

Example Quadrature Encoder with Setpoint Control Setup Procedure

Our customer operates a steel punch and wishes to automate the process using a rotary encoder. Texmate installed a Tiger 320 Series DI-50 meter with an IC03 quadrature encoder smart input module.

The encoder is used to set the length of steel plate being punched. The metal punch is activated using the module's smart relay output SR1.

The primary counter is read by channel 1 and configured in the x1 quadrature mode. This setting provides 1 to 1 encoder resolution. Setpoint 5 is configured to activate SR1 from the primary counter.

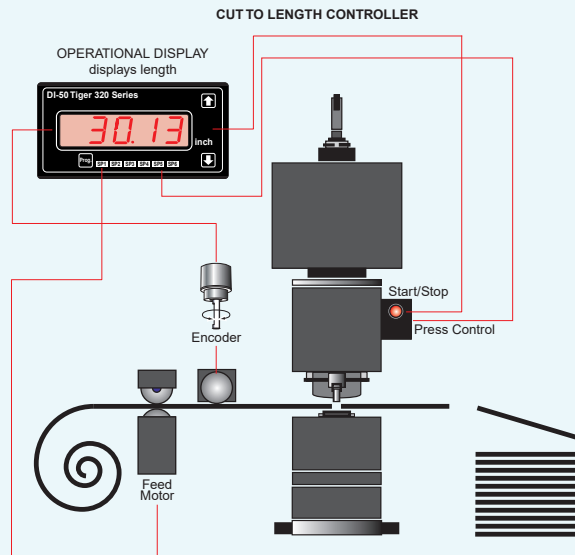

- 1 Select the encoder resolution quadrature x1 for the A & B counter functions in the 3rd digit, and no function for the C counter function in the 2nd digit:

In select then press button.

Display toggles between

Set to

- 2 Select the primary counter for CH1:

In select



Note, in the quadrature mode the primary counter is always used to output positional count and direction of rotation.

- 3 Set setpoint 5 (SP5) source to the primary counter with SR1 switch closure set to normally open (NO):

In select then press button.

Display toggles between

Set to

WARRANTY

Texmate warrants that its products are free from defects in material and workmanship under normal use and service for a period of one year from date of shipment. Texmate's obligations under this warranty are limited to replacement or repair, at its option, at its factory, of any of the products which shall, within the applicable period after shipment, be returned to Texmate's facility, transportation charges pre-paid, and which are, after examination, disclosed to the satisfaction of Texmate to be thus defective. The warranty shall not apply to any equipment which shall have been repaired or altered, except by Texmate, or which shall have been subjected to misuse, negligence, or accident. In no case shall Texmate's liability exceed the original purchase price. The aforementioned provisions do not extend the original warranty period of any product which has been either repaired or replaced by Texmate.

USER'S RESPONSIBILITY

We are pleased to offer suggestions on the use of our various products either by way of printed matter or through direct contact with our sales/application engineering staff. However, since we have no control over the use of our products once they are shipped, NO WARRANTY WHETHER OF MERCHANTABILITY, FITNESS FOR PURPOSE, OR OTHERWISE is made beyond the repair, replacement, or refund of purchase price at the sole discretion of Texmate. Users shall determine the suitability of the product for the intended application before using, and the users assume all risk and liability whatsoever in connection therewith, regardless of any of our suggestions or statements as to application or construction. In no event shall Texmate's liability, in law or otherwise, be in excess of the purchase price of the product.

Texmate cannot assume responsibility for any circuitry described. No circuit patent or software licenses are implied. Texmate reserves the right to change circuitry, operating software, specifications, and prices without notice at any time.

TEXMATE INC

1934 Kellogg Ave. • Carlsbad, CA 92008

Tel: 1-760-598-9899 • USA 1-800-839-6283 • That's 1-800-TEXMATE

Email: orders@texmate.com • Web: www.texmate.com