

## UNIVERSAL DIRECT PRESSURE SENSOR INPUT MODULE

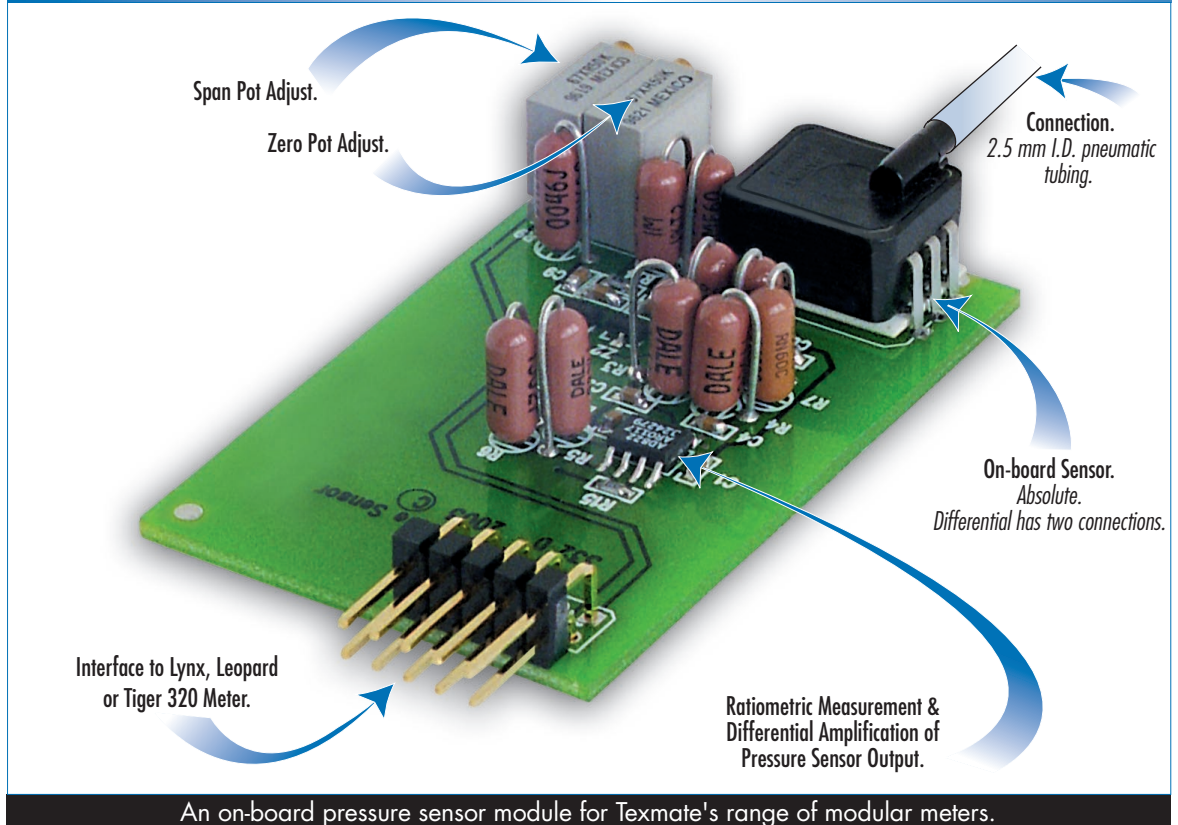

An on-board pressure sensor module for Texmate's range of modular meters.

A cost effective solution for pressure applications requiring monitoring and process control of non-corrosive, non-ionic working fluids such as air, dry gases and similar. The pressure sensor is available in absolute and differential models and pressure ranges from 0 to 100 psi. The input module interfaces directly with Lynx, Leopard, and Tiger 320 Series meters.

**Input Module Order Code Suffix**  
IGYZ

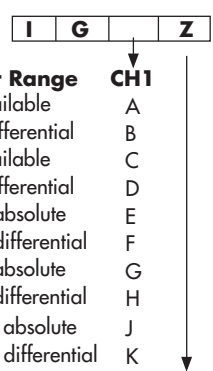

The last digit of the order code is always Z.

For example, IGDZ:  
**CHI** 5 psi, differential pressure.



Hardware Module Specifications	
Pressure Inputs Channel 1	Absolute or differential connections via 2.5 mm I.D. pneumatic tubing.
Pressure Ranges	0-1, 0-5, 0-15, 0-30, and 0-100 psi.
	Temperature compensated 0-50 °C, ± 0.4% Full Scale.
Max Pressure any Port	150 psi.
Repeatability	± 0.2% Full Scale typical.
Linearity/Hysteresis	± 0.2% Full Scale typical.
Output Voltage	± 2 V Full Scale.
Zero Adjust	Zero potentiometer.
Span Adjust	Span potentiometer.



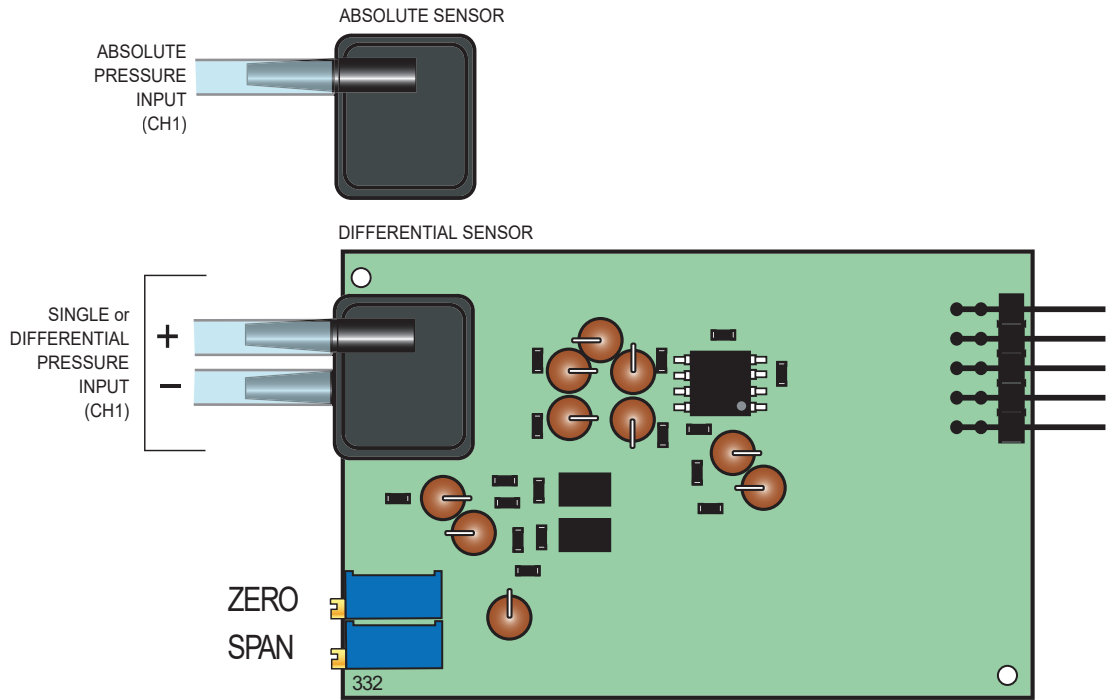

**Figure 1 – IGYZ Universal Direct Pressure Sensor Input Module Component Layout**

## Detailed Description

This module interfaces directly with Texmate's Tiger, Leopard, and Lynx range of modular controllers and panel meters. It has a single output that is an amplified and scaled version of the onboard direct pressure sensor.

The sensor can be ordered as either an absolute or differential pressure type. Gain setting resistors are factory installed to optimize the full scale output for each pressure range.

Contact Texmate when ordering to discuss your pressure range requirements.

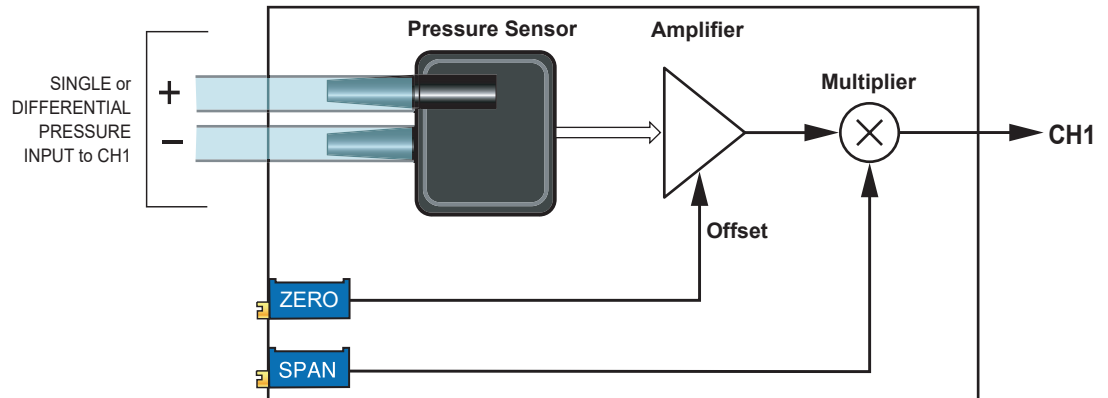

**Figure 2 – IGYZ Universal Direct Pressure Sensor Input Module Signal Flow Diagram**

## Tiger Controllers and Leopard Meter Relays



The Tiger and Leopard range use internal software functions to calibrate the span and zero offset. However, it may be necessary to adjust the span potentiometer to bring the maximum input signal within the full scale range of the instrument. The Lynx has no internal software calibration procedure. Calibration is done manually using both the zero and span potentiometers.

## Overrange Indications

### Lynx

When the input signal is beyond the full scale range of a Lynx meter, all the segments of each digit of the display flashes.

### Leopard

When the input signal is beyond the full scale range of a Leopard meter, the top segment of each digit on the display flashes. See Figure 3.

### Tiger

When the input signal is beyond the full scale range of a Tiger controller, the display flashes [OVER]. See Figure 3.

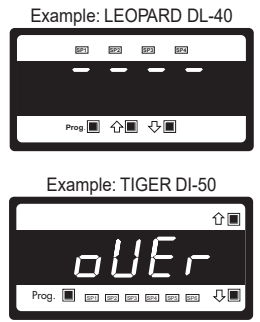

Figure 3 – Overage Indications

## Lynx Indicators



Lynx indicators are supplied to match the displayed full scale counts to the full scale input pressure.

Lynx indicators can display the following resolution for absolute and differential pressure ranges:

Pressure Range	Full Scale Display Counts	
	Absolute	Differential
1 psi	Not available	± 1.00
5 psi	Not available	± 5.00
15 psi	15.00	± 15.00
30 psi	30.0	± 30.0
100 psi	100.0	± 100.0

## Lynx Calibration Example

See Figure 4. For a certain application, a 15 psi pressure input may be required to read ± 2.00 counts on the meter display. Apply a zero pressure input or zero pressure differential. Using the zero potentiometer, adjust the zero pot until the display reads 0 counts.

Now apply the full scale pressure signal of 15 psi. Using the span potentiometer, adjust the span pot until the display reads 2.00 counts.

This procedure can be used to calibrate a Lynx over any of the specified input ranges by adjusting the full scale pressure signal and the full scale display counts to suit.

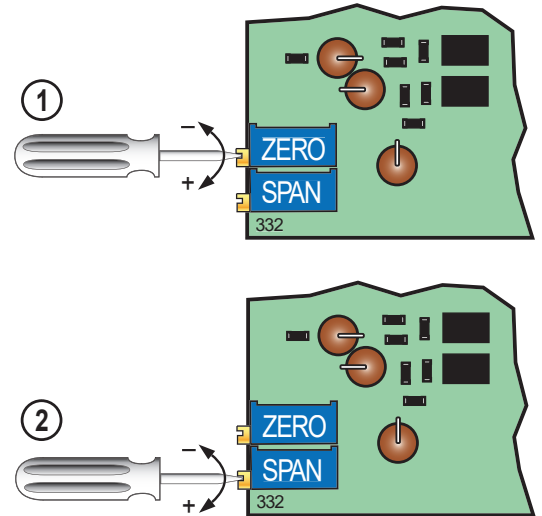

Figure 4 – Lynx Calibration Setting

## Leopard & Tiger Initial Setup

If an overrange condition exists, with the full scale pressure applied to the pressure sensor, turn the 15-turn span potentiometer counter-clockwise to decrease the signal until a reading appears on the display (See Figure 5). Now calibrate the instrument using the software calibration method or your instrument. See Leopard Calibration Example on Page 4 and Tiger Calibration Example on Page 6.

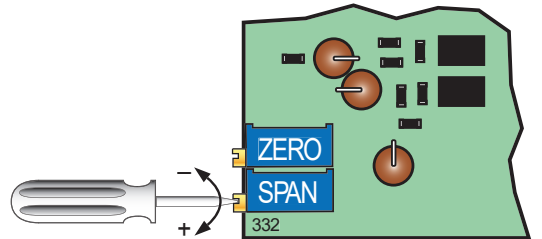

Figure 5 – Leopard & Tiger Initial Calibration Setting

## Leopard Meter Relay Calibration Example

In the following example, compressed air is supplied at a constant 80 psi to the pneumatics of an assembly line. If the air pressure becomes greater than 90 psi for an extended period damage can occur to the pneumatic seals.

A Leopard DL-40 meter relay has been installed to monitor the air with an IGYZ universal direct pressure input module set to 100 psi absolute pressure. A setpoint activates if the pressure exceeds 90 psi for more than 10 seconds, opens a relief valve, and sounds an alarm.

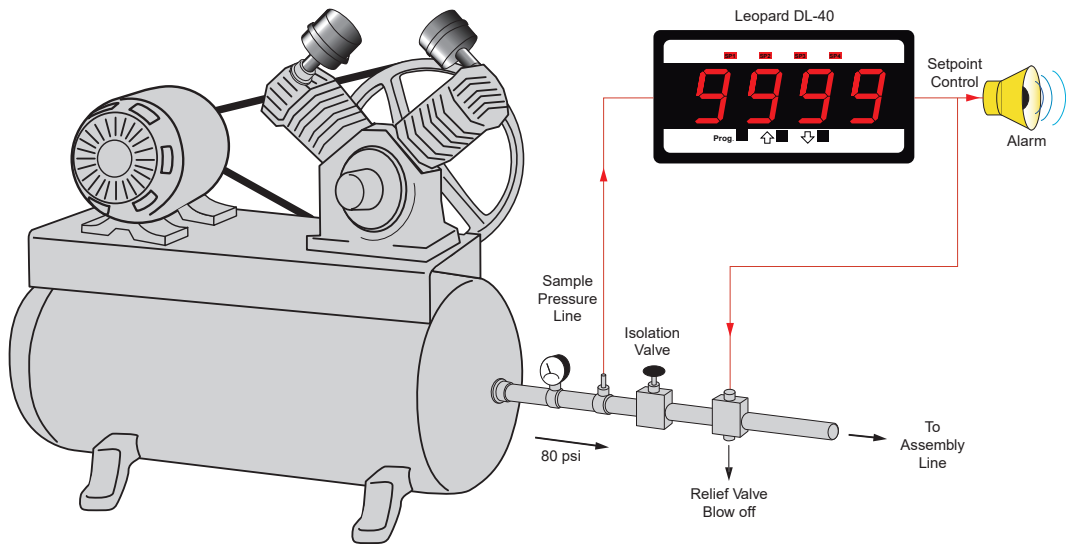

Figure 6 – IGYZ Universal Direct Pressure Sensor Leopard Calibration Example

### Procedure

With the compressor off and the air lines open, set the meter's zero calibration setting.

With the isolation valve closed and only the sample pressure line open, start the compressor and take it to 100 psi. With 100 psi at the meter, set the meter's span (full scale) setting.

The following example calibration procedure demonstrates calibrating the Leopard DL-40 meter with a zero setting of 0 counts, and a span (full scale) setting of 100 psi. See Figure 7 and the calibration procedure diagram opposite.

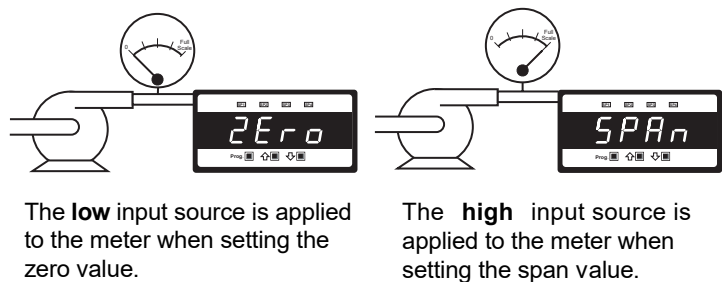
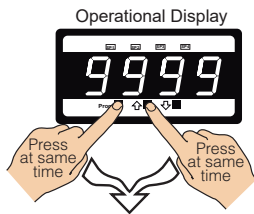

Figure 7 – Leopard 2-point Calibration Zero and Span Setting

**START HERE**

**Step 1**

Enter the Calibration Mode



**Step 2**

Select calibration [on]

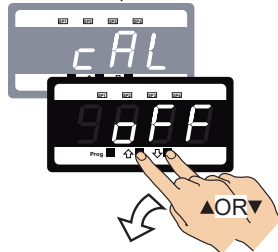

**Step 3**

Enter the next phase of the Calibration Mode



*Note: If there is no analog output installed the meter goes directly to the zero input setting mode (Step 6).*

**Step 4**

Select calibrate [iP]  
This bypasses the analog output range setting and calibration menu and selects the input 2-point calibration menu

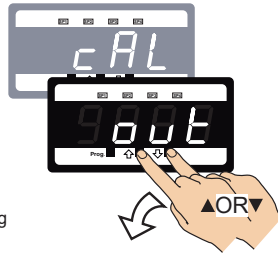

**Step 5**

Select [iP]

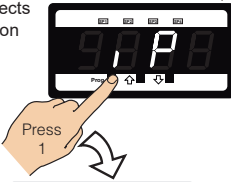

**Step 6**

6.1. Adjust the display to the desired reading for the zero input setting  
6.2. Apply the LOW (ZEro) input pressure (e.g 0 psi)

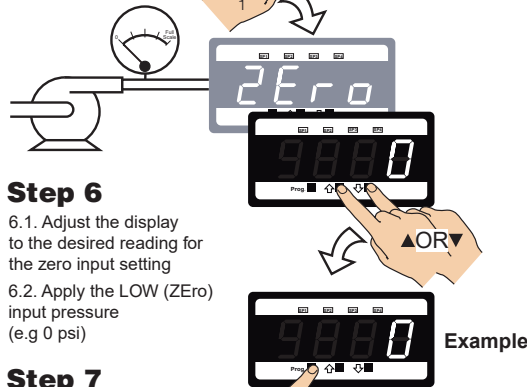

**Step 7**

Enter the span mode



**Step 8**

8.1. Adjust the display to the desired reading for the span input setting  
8.2. Apply the HIGH (SPAN) input pressure (e.g. 100 psi)

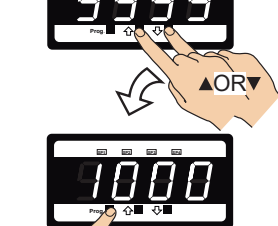

**Step 9**

Enter the decimal point setting mode



From Step 9

**Step 10**

Select the required decimal point setting (e.g. XXX.X)  
Decimal point settings:  
X:XXX  
XX:XX  
XXX:X  
XXXX:  
XXXX

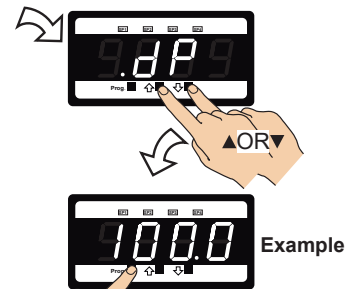

**Step 11**

Enter the brightness setting mode

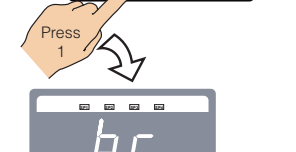

**Step 12**

Set the display to the required brightness

Display brightness settings:  
1 (Dull)  
2  
3  
4 (Bright)

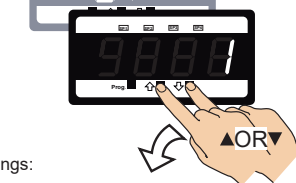

**Step 13**

If an analog output is installed, enter the analog output digital HIGH span range setting mode

*Note: If there is no analog output installed, the calibration settings are saved and the meter goes directly back to the operational display. See Step 17.*

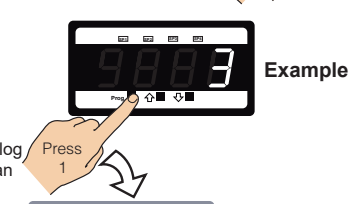

**Step 14**

Set the display counts you want to see for the analog output HIGH span setting

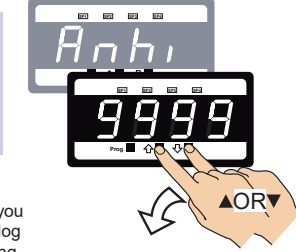

**Step 15**

Enter the analog output digital LOW span range setting mode

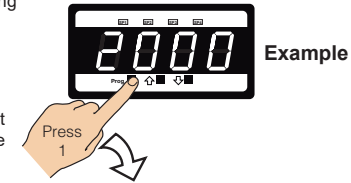

**Step 16**

Set the display counts you want to see for the analog output LOW span setting

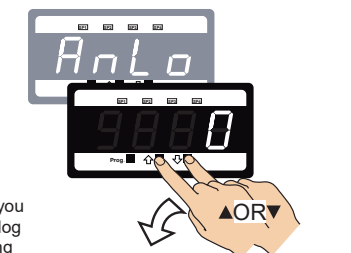

**Step 17**

Save the calibration settings and return to the operational display

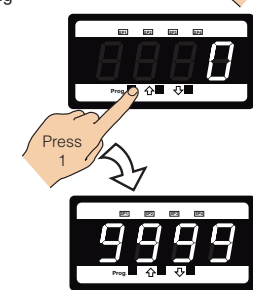

Operational Display

To Step 10

## Tiger Controller Calibration Example

In the following example, a Tiger 320 Series controller has been installed with an IGYZ universal direct pressure input module set to 15 psi differential pressure to monitor the efficiency of a filter mounted in an air duct. If the differential pressure becomes too great, the controller sounds an alarm. See Figure 8.

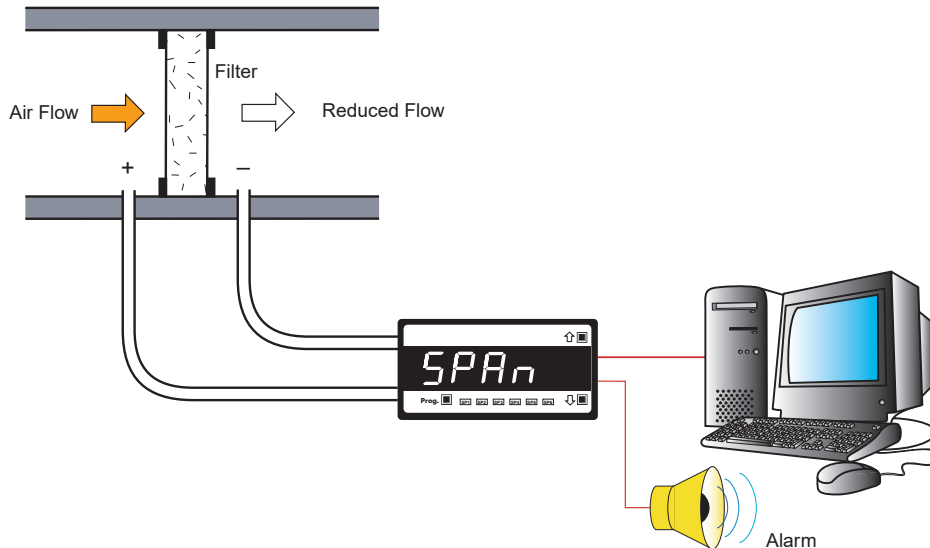

Figure 8 – IGYZ Universal Direct Pressure Sensor Tiger Calibration Example

### Procedure

Without the filter in place, zero channel 1.

Now apply 15 psi into the positive (+) differential input tube, while leaving the negative (-) input tube open to atmosphere.

The following example calibration procedure demonstrates calibrating the Tiger DI-50 meter with a zero setting of 0 counts, and a span (full scale) setting of 1500 counts for 15 psi on channel 1 (CH1). See Figure 9 and the calibration procedure diagram opposite.



The **low** input source is applied to the meter when setting the zero value.

The **high** input source is applied to the meter when setting the span value.

Figure 9 – Tiger 2-point Calibration Zero and Span Setting



#### Programming Tip

All displays shown in this example are for a 5-digit, 7-segment display. Using any other display type in the Tiger 320 Series range will look slightly different.

**START HERE**

Operational Display

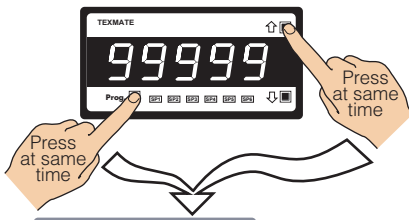

**Step 1**

Enter brightness mode



**Step 2**

Pass brightness mode and the enter calibration mode

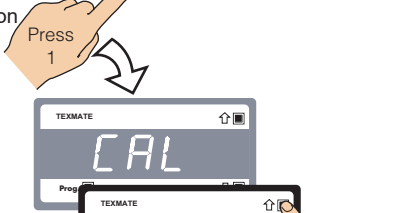

**Step 3**

Set calibration mode to [111]:  
 1st Digit = 1  
 Selects calibration procedures  
 2nd Digit = 1  
 Selects 2-point calibration  
 3rd Digit = 1  
 Selects CH1 for calibration

[111] for CH1  
 [112] for CH2  
 [113] for CH3  
 [114] for CH4

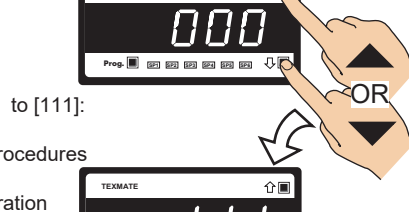

**Step 4**

Enter calibration mode [111] for 2-point calibration of CH1

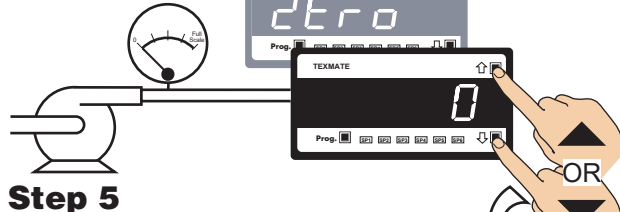

**Step 5**

5.1. Adjust the display to the desired reading for the zero input setting  
 5.2. Apply the LOW input pressure

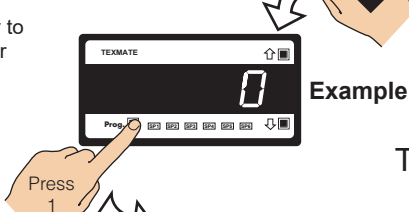

**Step 6**

Set the reading for zero load into the meter and enter the span mode

From Step 6

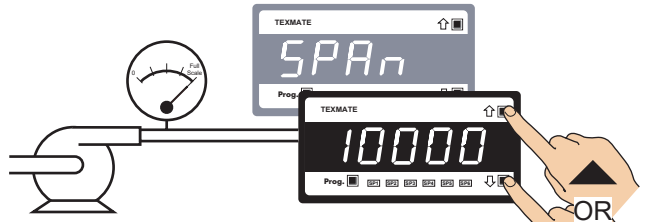

**Step 7**

7.1. Adjust the display to the desired reading for the span input setting  
 7.2. Apply the HIGH input pressure

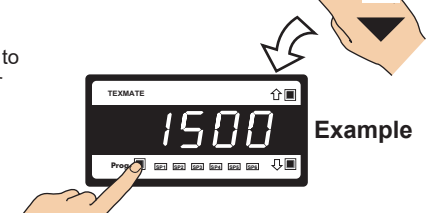

**Step 8**

Save the zero and the span settings and re-enter the calibration mode



**Step 9**

Select the no function calibration mode [000]

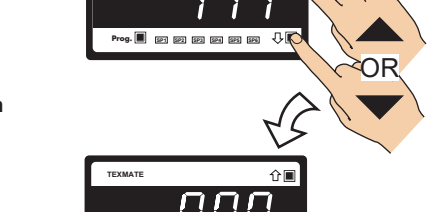

**Step 10**

Save calibration mode [000] setting and enter Code 1

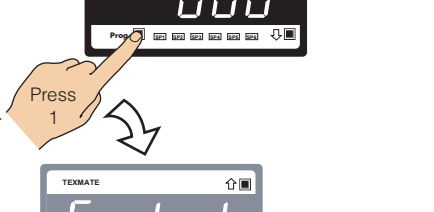

**Step 11**

Exit code 1 and return to operational display

To Step 7



Operational Display

---

**WARRANTY**

Texmate warrants that its products are free from defects in material and workmanship under normal use and service for a period of one year from date of shipment. Texmate's obligations under this warranty are limited to replacement or repair, at its option, at its factory, of any of the products which shall, within the applicable period after shipment, be returned to Texmate's facility, transportation charges pre-paid, and which are, after examination, disclosed to the satisfaction of Texmate to be thus defective. The warranty shall not apply to any equipment which shall have been repaired or altered, except by Texmate, or which shall have been subjected to misuse, negligence, or accident. In no case shall Texmate's liability exceed the original purchase price. The aforementioned provisions do not extend the original warranty period of any product which has been either repaired or replaced by Texmate.

**USER'S RESPONSIBILITY**

We are pleased to offer suggestions on the use of our various products either by way of printed matter or through direct contact with our sales/application engineering staff. However, since we have no control over the use of our products once they are shipped, **NO WARRANTY WHETHER OF MERCHANTABILITY, FITNESS FOR PURPOSE, OR OTHERWISE** is made beyond the repair, replacement, or refund of purchase price at the sole discretion of Texmate. Users shall determine the suitability of the product for the intended application before using, and the users assume all risk and liability whatsoever in connection therewith, regardless of any of our suggestions or statements as to application or construction. In no event shall Texmate's liability, in law or otherwise, be in excess of the purchase price of the product.

Texmate cannot assume responsibility for any circuitry described. No circuit patent or software licenses are implied. Texmate reserves the right to change circuitry, operating software, specifications, and prices without notice at any time.

---

**TEXMATE INC**

1934 Kellogg Ave. • Carlsbad, CA 92008

Tel: 1-760-598-9899 • USA 1-800-839-6283 • That's 1-800-TEXMATE

Email: [orders@texmate.com](mailto:orders@texmate.com) • Web: [www.texmate.com](http://www.texmate.com)

For product details visit [www.texmate.com](http://www.texmate.com)