



PC-45X 4 1/2 DIGIT EVENT COUNTER

A Versatile Event Counter/Totalizer Featuring 19999 Counts with Overrange Indication, or 9999 Counts with Cascade Output, Contact Closure or Logic Signal Input, High Contrast LCD, 4-6 V DC Powered with Outputs for User Supplied Ni-CAD Battery Back-Up, Capable of Signal Powered Operation.

DESCRIPTION

Texmate's model PC-45X event counter/totalizer is a versatile, low cost DC powered LCD meter which features three user programmable count inputs and count rates. All count inputs are compatible with open collector sensing devices. The standard low range SPST or SPDT dry contact closure rate is 0~6000 CPM (0~100 CPS). The SPST switch input mode utilizes a low pass filter and a Schmitt trigger with 15% hysteresis for debouncing. The SPST switch input mode which utilizes an R-S Flip-Flop for debouncing can accept high speed dry contact closure rates of 0~600,000 CPM (0~10,000 CPS) if the low pass filter is reduced or eliminated. The PC-45X also accepts 3-30VDC positive going pulses or AC signal inputs up to 15MHz. A 500mV hysteresis aids the accurate counting of slow changing waveforms.

Other features include logic controls such as inhibit, reset, display hold, carry output, overrange output, and outputs to continuously trickle charge an external user supplied Ni-Cad battery back-up which will prevent loss of data in case of intermittent or power-out situations. The unit is also capable of being programmed for signal powered operation. There are four programmable decimal points, and unlimited cascading to achieve multiples of four digits using two or more PC-45X units. In this type of operation only the left most meter will display a fifth digit.

The display hold feature enables the user to latch the display while the counter continues counting. Without affecting the latched display, the counter may be reset to zero by the reset control or the counting function may be stopped and started by the inhibit control. When the Display Hold is released, the data present in the counter at that time is instantly displayed.

With external logic control, the PC-45X may be used as a frequency counter, RPM indicator or period counter. The large 0.48" LCD display has excellent readability in both high and low ambient light conditions, and its low power consumption 5VDC-2mW or signal powered operation makes it especially useful in remote locations.

When PC-45X is programmed for signal powered operation (9 to 600V p-p @ 400µA), the back-up battery must be used unless the input signal pulses are continuous because power is required to maintain the count logic.

SPECIFICATIONS

COUNT INPUTS

- SPST Contact Closure:** 0~6000 CPM (100Hz) with 500Hz Low Pass filter and Schmitt Trigger set at 15% Hysteresis
- SPDT Contact Closure:** 0~6000 CPM (100Hz) with 500Hz Low Pass filter and R-S Flip-Flop. 0~600,000 CPM (10kHz) with filter removed
- 3-30V AC or DC Pulse:** 0~500kHz with Schmitt Trigger threshold of 2V and 500mV Hysteresis. If the internal 100kΩ overvoltage protection resistor is removed the max count is 0~15MHz
- Open Collector Sensing:** All inputs are compatible with open collector sensing devices
- Over Voltage Protection:** Pins 6, E & F are protected up to ±100V peak overload with internal 100kΩ resistors.
Caution: All other input or control pins are NOT PROTECTED against High Voltage.

CONTROLS & OUTPUTS

- Reset:** Dry Switch closure to ground or Logic Low "0" input for min. 3µS resets counter to zero. (50µA pull-up current is provided).
- Inhibit Count:** Dry Switch closure to ground or Logic Low "0" input will prevent the D flip-flop on the count input from operating (10µA pull-up current is provided)
- Display Hold:** An Open input or Logic High "1" input on this pin "freezes" the display while the counter continues to operate independently. A Dry Switch closure to ground or Logic low "0" input for min. 3µS updates the display (10µA pull up current is provided.) For continuous display of the counter input the display hold function should be connected to ground
- Carry Output:** Internal solder pad SP2 provides a logic signal output that occurs each 10,000 counts for cascading the count in 4 digit multiples
- Overrange Output:** Internal solder pad SP1 goes to Logic High "1" when the count exceeds 20,000 counts
- Display:** 0.48" LCD Max. 19999
- Decimal:** User programmable to 4 positions
- Overload Indications:** All digits blank except decimal points
- Back-Up Battery:** 200µA output is provided to trickle charge a user supplied 3.6V Ni-Cad battery
- Power Requirements:** Regulated 4VDC to 6VDC at 400µA or Signal Powered
- Operating Temperature:** -20°C to +60°C

ORDERING INFORMATION

Order Part No.

STANDARD 1999 COUNTS EVENT COUNTER
ACCESSORIES: Edge Connector (20 pin solder tabs)

PC-45X
CN-L10

CONNECTOR PINOUTS

The Texmate Model PC-45X interconnects by means of a standard PC board edge connector having two rows of 10 pins, spaced on 0.156" centers. Connectors are available from Texmate, or from almost any connector manufacturer.

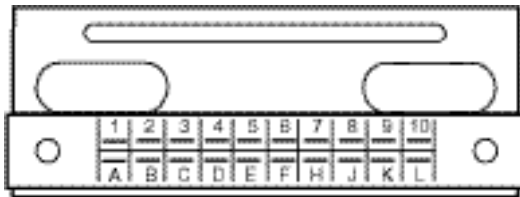

REAR VIEW OF METER CASE

- | | |
|--|---|
| A - Back Plane Input/Display Test | 1 - Back Plane Output |
| B - Decimal Select (1XXX.X) | 2 - Decimal Select Common |
| C - Decimal Select (1XX.XX) | 3 - Decimal Select (1.XXXX) |
| D - Decimal Select (1X.XXX) | 4 - Backup Battery Positive Terminal |
| E - SPDT Switch Input Enable | 5 - Inhibit Input |
| F - SPST/SPDT Switch Input | 6 - 3-30V AC/DC Pulse Input |
| H - Display Hold | 7 - Reset Input |
| J - System/Power Ground Input | 8 - +5VDC System Power Input |
| K - No Connection | 9 - No Connection |
| L - No Connection | 10 - No Connection |

CAUTION: This meter employs high impedance CMOS inputs. Although internal protection has been provided for several hundred volt overloads, the meter will be destroyed if subjected to the high kilovolts of static discharge that can be produced in low humidity environments. Always handle the meter with ground protection.

FUNCTIONAL DIAGRAM

The diagram below depicts the Model PC-45X in its standard 2V F.S. form with all component values indicated for this mode of operation. Variations from the standard for use in special applications will be found under the heading Typical Application Circuits & Connection Instructions.

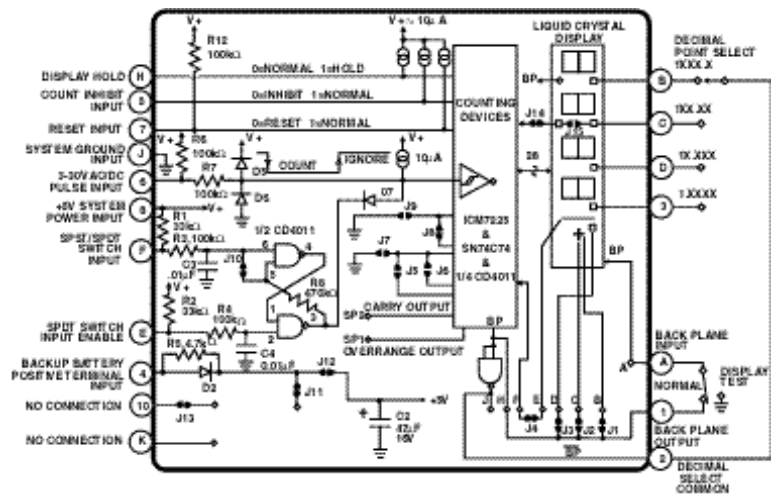

PIN DESCRIPTIONS

Pin A - Back Plane input/Display Test: Pin A is connected to the display's back plane which forms the common base of the LCD capacitance structure. Join Pin A to Back Plane Output Pin 1 for normal operation. For Display Test connect Pin A instead to System Ground Pin J and all operative segments will turn on. **Caution:** The Display Test function is only intended for momentary operation. Continuous application of Display Test will, in time, damage the display. SEE PAGES 5 & 6 FOR A DETAILED EXPLANATION OF LCD OPERATION.

Pin B, C, D AND 3 - Decimal Select: Decimal points may be displayed as required by connecting the appropriate pin to Decimal Select Common Pin 2. Any number of decimal points can be turned on at the same time. An open circuit will turn off the decimal points. However, static current pickup and/or PCB leakage of more than 100nA can cause decimal points to turn on undesirably. Therefore, it is recommended that the unused decimal points be connected to Back Plane Output Pin 1 either directly or by a resistor of less than 5MΩ to insure an off condition. **Caution:** Any DC component introduced to the display drive circuitry can, in time, cause permanent damage. PLEASE READ PAGE 5 & 6 FOR DETAILED EXPLANATION OF LCD OPERATION.

Pin E - SPDT Switch Input Enable: To use Pin E, J10 must be opened. This creates an R-S Flip Flop for failsafe switch closure counting. After an input is received on Pin F, no further count inputs will be accepted until Pin E is enabled by a contact to System Ground Pin J. When using a SPDT switch, connect the normally closed terminal to Pin E, the normally open terminal to Pin F, and the common terminal to System Ground Pin J. A low pass filter is provided to reject high frequency noise for operation within the range of 0~6000 CPM (100Hz). For high speed contact closure operation, up to 10,000 counts per second max., C3 and C4 must each be reduced to 100pF or removed entirely.

Pin F - SPST/SPDT Switch Input: Connect a dry contact switch between Pin F and System Ground Pin J or a count on contact closure rate of 0~6000 CPM (100Hz). Contact debouncing is provided by a low pass filter and a Schmitt trigger factory set with a 15% Hysteresis. This standard contact closure input mode of operation is designed for up to 100 counts per second or 6000 CMP. Faster counting rates can be implemented by proportionally reducing the low pass filters time constant: for example, 0~200 counts per second can be counted if C3 is changed to 5000pF. For high speed contact closure operation, a SPDT switch must be used (see Pin E).

Pin H - Display Hold: Pin H controls a latch between the display driver circuit and the counter circuit. For normal continuous display of the count function Pin H must be connected to System Ground Pin J or have Logic Low "0" applied. If Pin H is left open (a 10μA pull-up current is provided), or if Logic High "1" is applied, the display register will latch up and hold the count displayed. The counter section will continue independent operation and may be reset or inhibited without affecting the display hold function. To refresh or update and hold the display, as would be required for RPM or frequency measurement applications, pin H must be connected to System Ground Pin J or have logic Low "0" applied for a minimum of 3μS.

Pin J - System /Power Ground Input: Negative terminal of +5VDC power should be connected to Pin J. All digital signals, controls, outputs and back-up battery should be returned to System/Power Ground Input Pin J. **Caution:** Damage may occur to the CMOS devices in this counter if voltage inputs from external sources are applied to the control and signal input pins before the counter's own power supply is established.

Pin K, L - No Connection: No circuit connections are made on these pins.

Pin 1 - Back Plane Output: Liquid crystal displays are operated from an AC signal. Back Plane Output Pin 1 provides a square-wave signal of 60~160Hz that must be connected by the user to back plane input Pin A for normal operation. Pin 1 is internally connected to the LCD back plane which is the common base of the LCD capacitance structure. Those segments that are driven 180° out-of-phase with the back plane will turn on. Those segments that are driven in-phase with the back plane will turn off. PLEASE READ PAGES 5 & 6 FOR A DETAILED EXPLANATION OF LCD OPERATION.

Pin 2 - Decimal Select Common: Pin 2 is 180° out-of-phase with back plane output Pin 1. Thus it serves as a common for the decimal select Pin B, C, D, and 3. To turn on any required decimal point, connect the appropriate Decimal Select Pin to Decimal Select Common Pin 2.

Pin 4 - Backup Battery Positive Terminal: When the unit is operated from +5VDC power, a standard 3.6V Ni-Cad battery can be used as a backup battery by connecting the positive terminal of the battery to Pin 4 and negative to System/Power Ground Input Pin J.

Pin 5 - Inhibit Input: For normal operation Pin 5 is left open or applied to logic high "1" (10μA pull-up current is provided). If Pin 5 is connected to System/Power Ground Input Pin J or has logic Low "0" applied, the count input section of the counter circuit is disabled and will not accept input signals until Pin 5 is released from Pin J or has Logic High "1" applied.

Pin 6 - 3-30V AC/DC Pulse Input: Pin 6 provides a direct input to the counter for externally generated input signals. The input circuit incorporates a Schmitt Trigger with a 2.0V threshold and 0.5V of hysteresis. A 100kΩ pull resistor R6 and a 100kΩ overvoltage protection resistor R7 are also incorporated into the circuit. The count occurs on the negative going edge of a positive input signal. Logic Low "0" = 0 to +1.5V. Logic High "1" = 2.5 to +30V. The 100kΩ overvoltage protection resistor R7 will protect the counter from overvoltages up to a peak of ± 100V. **Caution:** See Pin J for precautions necessary to avoid damage to the counter from externally generated signals. The overvoltage protection resistor limits the maximum count speed to 0~500KHz. If the input signal is limited externally to 0~+5VDC Logic Levels and the overvoltage protection resistor R7 is replaced with a jumper, the counter can typically operate up to 15MHz.

Pin 7 - Reset Input: For normal accumulative counting Pin 7 is left open or applied to Logic High "1" (50μA pull-up current is provided). When Pin 7 is connected to System/Power Ground Input Pin J or has Logic Low "0" applied the counter will reset to zero.

Pin 8 - +5VDC System Power Input: The regulated 4 to 6VDC, 400μA Power Supply is connected to Pin 8. Low power consumption of 1.6 to 2.4mW enables the meter to be operated from various power sources with simple voltage regulating circuitry. The positive input terminal of the power supply is connected to Pin 8, the negative terminal to System/Power Ground Input Pin J.

Pin 9, 10 - No Connection: No circuit connections are made on these pins.

COMPONENT LAYOUT

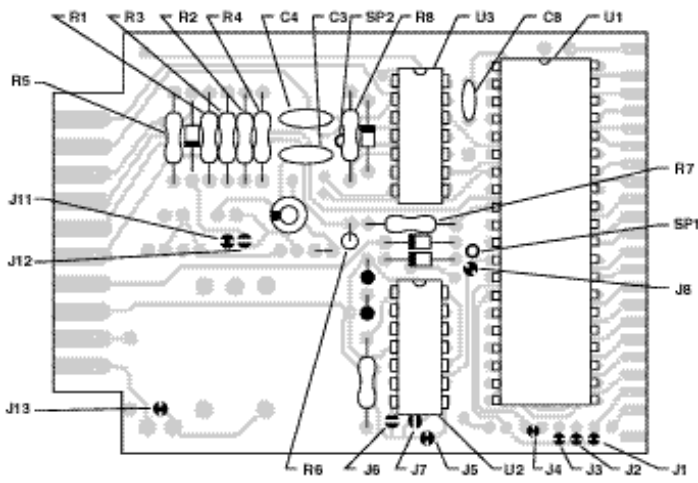

COMPONENT SIDE

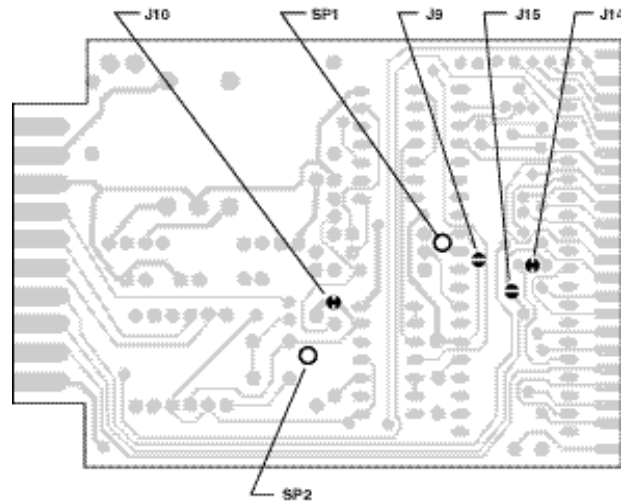

SOLDER SIDE

TYPICAL APPLICATION CIRCUITS & CONNECTION INSTRUCTIONS

The PC-45X may be used in a wide variety of configurations. The following circuits illustrate some of the possibilities and demonstrate the exceptional versatility of Texmate products. Components called for in the applications which are not part of the standard meter may be supplied by the user or in some cases purchased from Texmate. The circuit diagrams explain the basic pinout connections required for each application. Unless otherwise specified, the diagrams will show the component values and solder junctions that would normally be installed on a standard 2V range meter. For those applications which have alternative ranges and/or input configurations, the required component values and any modifications are described in the text. **NOTE:** Use of these application circuits is entirely at the risk and responsibility of the user and any user modification of the meter may at the discretion of Texmate, void the warranty. (See rear page for user's responsibility and warranty details.) The following legend applies to all application circuits: 1) optional component positions are shown in dotted lines; 2) internal solder junctions are shown by for a closed junction or for an open junction; 3) a mechanical switch is shown by

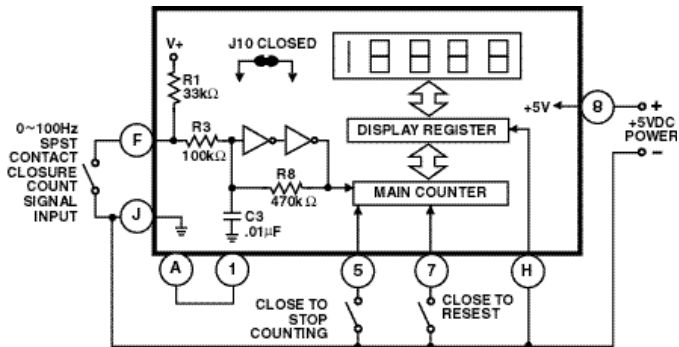

COUNT INPUT WITH SINGLE CONTACT SWITCH CLOSURE

A mechanically coupled single pole single throw contact closure can be used as a count input device for count rates up to 6000CPM (100Hz). The contact noise debouncing circuit consists of a low-pass filter and a Schmitt Trigger with 15% Hysteresis. If required, a higher count rate of 0~400 Hz can be achieved by reducing C3 to 2500pF

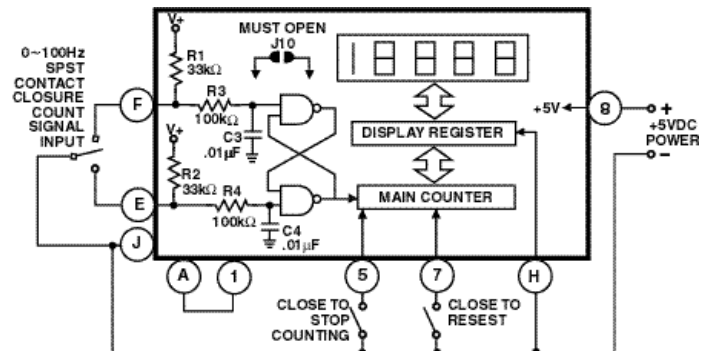

DOUBLE CONTACT CLOSURE COUNT INPUT

A mechanically coupled single pole double throw contact closure can be used as a count input device when J10 is opened. The contact noise debouncing circuit consists of a low-pass filter and a R-S flip-flop. After a count input is created making the connections between Pin F and Pin J, no further count inputs will be accepted until a contact is made between Pin E and Pin J. For higher count rates up to 0~600,000 CPM (10KHz) reduce C3 and C4 to 2500pF or remove entirely.

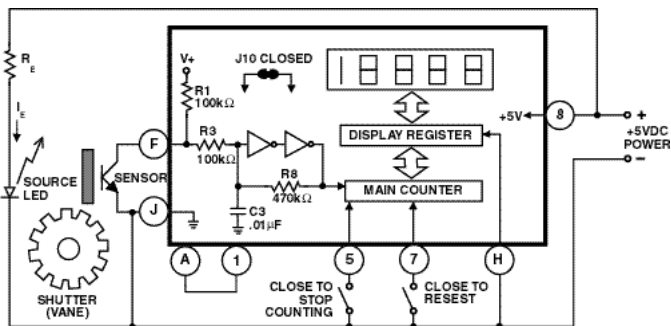

OPTO-ELECTRIC COUNT INPUT

A solid-state opto-electric NPN device can be interfaced directly to the event counter. External power maybe required to power the LED section of the device if more than 5mA is required. Note: R1 can be changed to match the sensitivity of the photosensor.

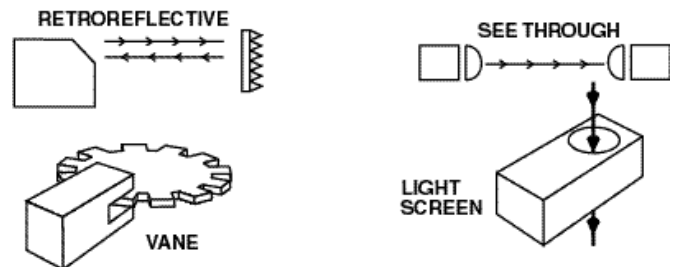

MOST COUNT OUTPUT DEVICES CAN BE DIRECTLY INTERFACED

Photoelectric devices, contact closure, switches, NPN open collector transistors, and voltage pulses up to 100 V can be used directly with Model PC-45X without expensive and complicated interfacing circuitry.

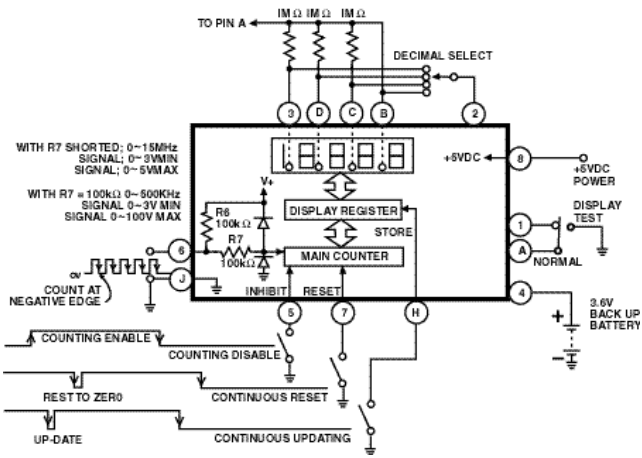

3-30 AC/DC PULSE INPUT AND HIGH FREQUENCY +5VDC LOGIC LEVEL INPUT

The input circuit incorporates a Schmitt Trigger with a 2.0V threshold and 0.5V of hysteresis. The count occurs on the negative going edge of an input signal. R6 acts as a pull-up resistor. R7 provides overvoltage protection to a peak of ±100V. For 0~15MHz operation from externally limited +5VDC logic level signals, replace R7 with a jumper.

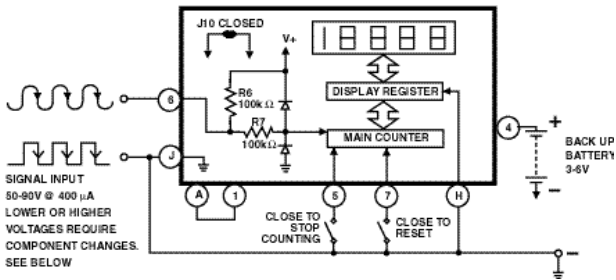

SIGNAL POWERED OPERATION

When the PC-45X is programmed for signal powered operation (9 volts peak-to-peak to 600 volts peak-to-peak), the input signal pulses must be continuous or the back-up battery must be used to maintain the count logic. (See table below for changes necessary in resistance value of R7 for various peak-to-peak signal voltages.) **Caution:** Input signal voltages must be limited to avoid damage to the counter when the value of R7 is reduced below 100kΩ.

TABLE FOR R7 RESISTANCE VALUE CHANGES

PEAK-TO-PEAK SIGNAL INPUT VOLTAGE	R7 RESISTANCE VALUE
9- 15	Shorted
15- 25	10K
25- 50	47K
50- 90	100K
90-130	220K
130-200	330K
200-280	470K
280-600	680K

(NOTE: All voltages are peak-to-peak value and not RMS)

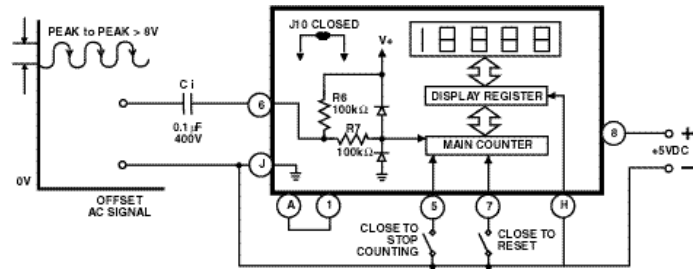

OFFSET AC-SIGNAL INPUT MODE

An Isolation Capacitor C, is installed externally to isolate the offset voltage. The meter is then AC coupled so that the counter can be employed to measure an AC signal that is carried on an offset DC voltage.

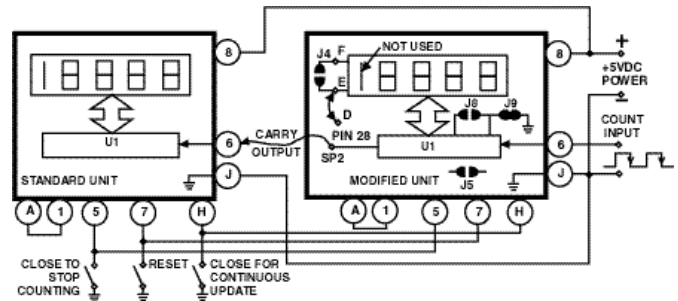

CASCADING THE UNIT

Open J5 and J8 and close J9 to disable overrange indication feature. Open J4 and jumper solder pads E & D to disable the MSD 1's to convert the first counter to a meter 9999 count mode. Join SP2 of the first counter to Pin 6 of the cascading counter to provide a total of 19999~9999 counts maximum.

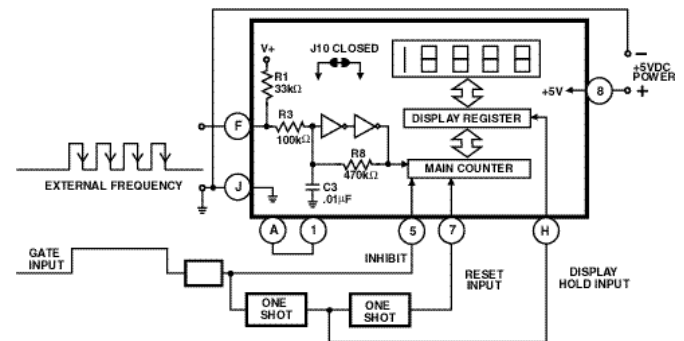

EXTERNAL LOGIC CONTROL PERMITS OPERATION AS A PERIOD COUNTER OR REQUENCY/RPM METER

THEORY AND APPLICATION OF LIQUID CRYSTAL DISPLAYS

The field-effect liquid crystal display is the most advanced and reliable liquid crystal display available today. Its operation depends on changing the optical properties of the liquid crystal by applying an electric field. The effect of this change is in turn, made visible by polarizers placed on each side of the display cell.

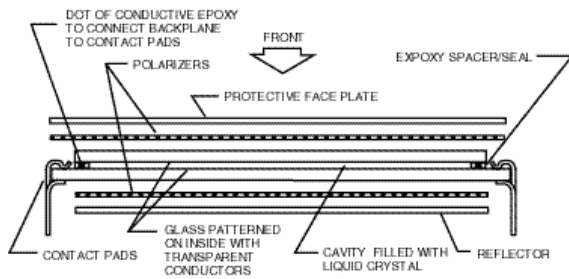

FIGURE 1. LCD Cross-Section

Liquid crystal displays are inherently reliable and thousands of Texmate's proprietary, customized LCD displays have been in continuous use throughout the world often in harsh environmental conditions for many years. An understanding of the simple precautions outlined here will provide many years of reliable maintenance-free use.

DISPLAY CONSTRUCTION AND OPERATION - The best description of liquid crystal is that is an ordered fluid of a class called nematic. Nematic fluids of the type used for liquid crystal displays consist of cigar-shaped organic molecules with the long axis of each molecule pointing in the same direction. The display cell is constructed from two pieces of glass coated on the inner side with transparent indium oxide conductors, as shown in Fig.1. Each of the transparent conductors on the inside of the larger rear glass piece is shaped to form the individual segments of the display and are terminated on individual contact pads. The single conductor on the inside of the front glass piece is shaped so as to be common to all the segments on the rear glass. Traditionally this common conductor is usually referred to as the "back plane". The common back plane is connected to the two left most (viewed from the front) contact pads by a small dot of conductive epoxy imbedded in the spacer/seal. The glass surfaces are also specially treated to align the liquid crystal molecules in a particular direction. Alignment is parallel to the plane of the glass, with the alignment direction of the top rotated 90° relative to the alignment of the bottom plate. This causes the cigar-shaped liquid crystal molecules in the cell to assume a twisted orientation, when viewed from top to bottom. As shown in Fig. 2, the plane of polarization of polarized light will follow this twist and emerge from the cell rotated 90°. Thus, when the cell is placed between crossed polarizers, the polarizers will transmit light. When an electric field is applied to the transparent conductors on the inside of the glass cell, the liquid crystal molecules will physically move and reorient themselves parallel to the field. The 90° twist is then destroyed, and that portion of the cell between the conductors will appear dark. Conversely, when the cell is placed between parallel polarizers light cannot be transmitted and the entire display will appear dark. When the electric field is then applied the segments formed by the transparent conductors will then appear light against a dark ground.

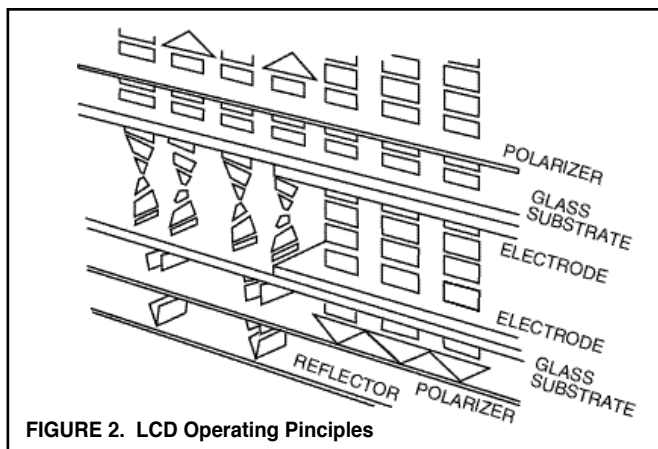

FIGURE 2. LCD Operating Principles

ELECTRICAL CHARACTERISTICS - Electrically, liquid crystal displays function like capacitors and, unlike LED's, are driven with an AC signal. This AC signal is necessary to maintain the electric field required to rotate the liquid crystal molecules. The LCD drive circuitry used for Texmate displays puts out a 60Hz square wave signal which is truly symmetrical and contains no DC components. Fig. 3 shows the typical AC drive signal's relationship between the common back plane and the individual segment elements. A segment is turned on when its drive signal is 180° out of phase with respect to the back plane. A segment is turned off when its drive signal is in phase with the back plane so that there is no net voltage between the back plane and the segment. Fig. 4 explains operation of the internal logic circuitry used to create the AC drive signal described in Fig. 3.

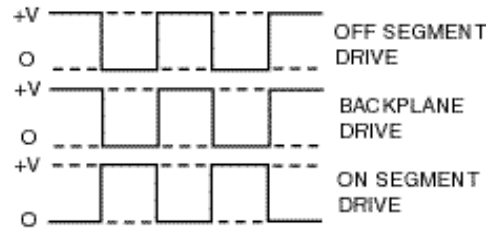

FIGURE 3. Typical AC Drive Signals

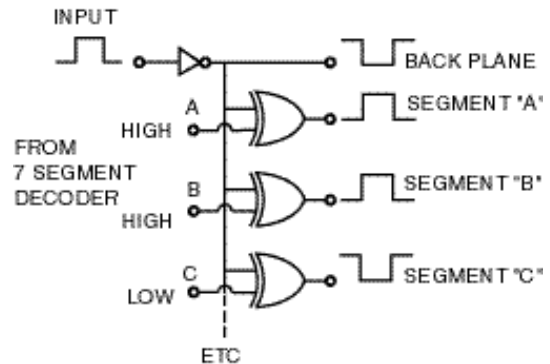

FIGURE 4. Exclusive-Or Drive Circuit

CAUTION - If a DC component is introduced into the display, electrolysis occurs and the transparent conductors which form the individual display elements will, in time, be destroyed. A DC component can be created by leakage or inadvertent connection to system ground of unused display elements such as descriptors and decimal points. For this reason it is recommended that unused display elements be connected to the back plane output drive pin which is provided on all Texmate LCD meters. The back plane signal will then drive these unused elements to an off condition. Short term application of a DC signal will not damage the display and, in fact, the display test function in most Texmate meters utilizes a DC signal to light up all segments for test purposes. This function, however, is only intended for momentary usage and if left activated for longer than 24 hours, damage to the display will occur.

TEMPERATURE SPECIFICATIONS - The extremely pure state-of-the-art LC materials used in Texmate displays provide a wide operating temperature range of -10°C to +60°C and a storage temperature range of -30°C to +70°C. Maintaining the display at temperatures above 70°C for sustained periods (days), or above 100°C for shorter times (minutes) can cause permanent damage of the LC material and/or polarizing film. At the low end of the temperature range, there is no fixed breakdown temperature. Instead, the display response time increases as molecular movement is slowed down due to the increased viscosity of the LC fluid. At approximately -15 to -20°C the LC compound undergoes first- or second-order phase changes and ceases to operate. Such changes, however, are reversible and not damaging. For example, LCD'S immersed in liquid nitrogen have returned to normal operation after a brief warmup period.

THEORY AND APPLICATION OF LIQUID CRYSTAL DISPLAYS (CONTINUED)

HUMIDITY SPECIFICATIONS - The polarized film used in LCD displays can be damaged by combinations of high temperature and high humidity, i.e., 85% RH at 50°C for 96 hours. Although these extreme conditions are rarely encountered in actual use. Texmate has provided for easy removal and replacement of polarizers and reflectors (see Fig. 5). The front polarizer is a loose piece and the combination rear polarizer and reflector can be slid out from the space between the LCD and the PC board. Spare replacement polarizers are available from Texmate. The polarizers normally provided with the meter as standard provide a reflective display mode. That is the background appears white and the segments appear black. Substitute rear polarizer/reflectors can be ordered with the opposite polarization plane. This will cause the display to become transmissive, with a black foreground and white segments. The polarization plane of the front polarizer is never changed from horizontal because although to the naked eye the display would operate perfectly if it were changed, a person viewing the display through polarized sunglasses would be unable to read any segments as the entire display would appear black.

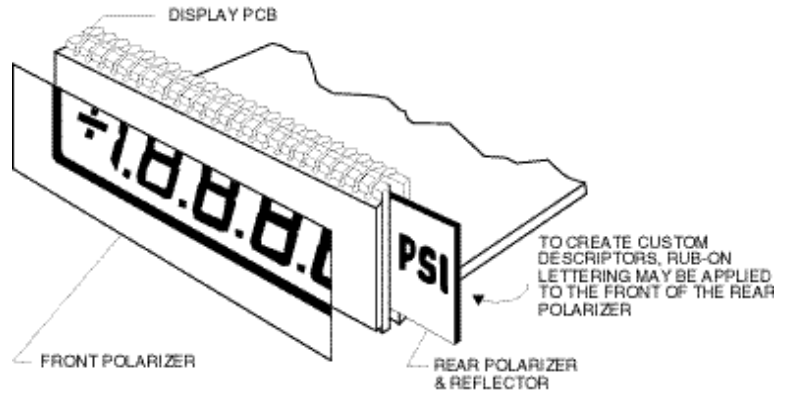
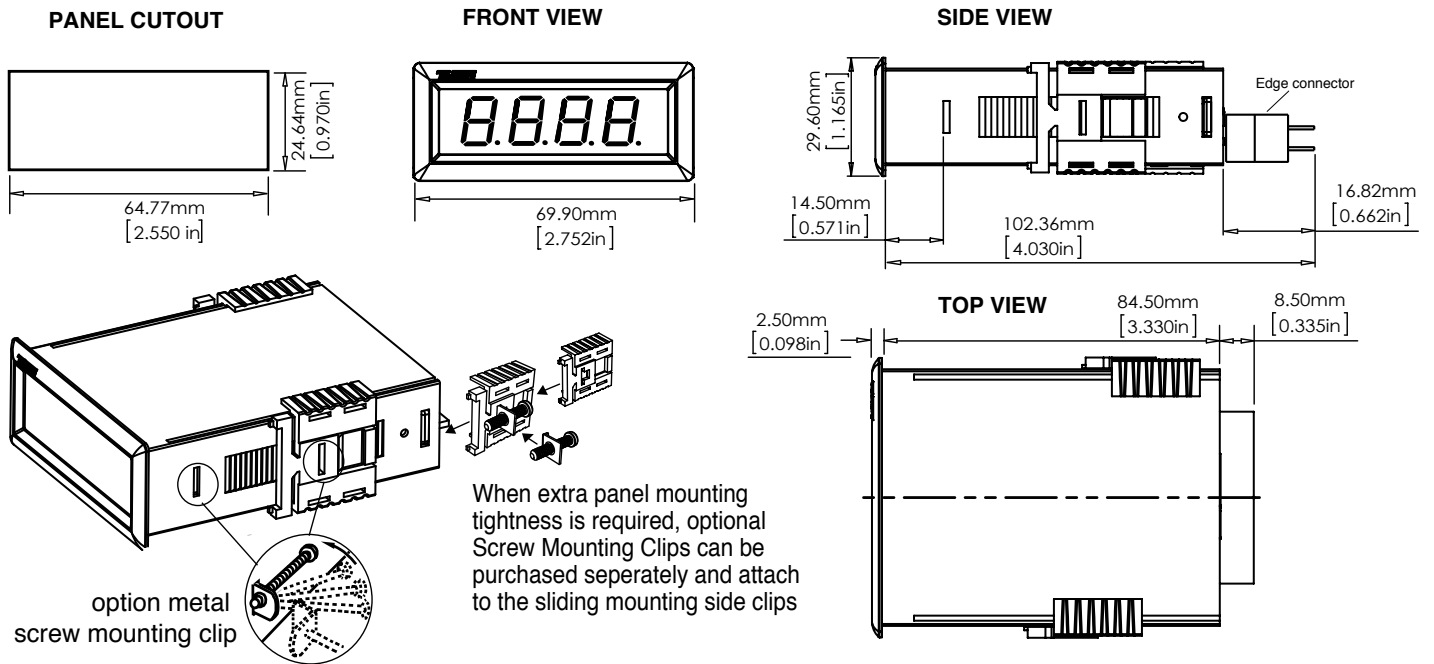

FIGURE 5. Replaceable Polarizers & Reflector Assembly

Case Dimensions and Panel Cutouts



WARRANTY

Texmate warrants that its products are free from defects in material and workmanship under normal use and service for a period of one year from date of shipment. Texmate's obligations under this warranty are limited to replacement or repair, at its option, at its factory, of any of the products which shall, within the applicable period after shipment, be returned to Texmate's facility, transportation charges pre-paid, and which are, after examination, disclosed to the satisfaction of Texmate to be thus defective. The warranty shall not apply to any equipment which shall have been repaired or altered, except by Texmate, or which shall have been subjected to misuse, negligence, or accident. In no case shall Texmate's liability exceed the original purchase price. The aforementioned provisions do not extend the original warranty period of any product which has been either repaired or replaced by Texmate.

USER'S RESPONSIBILITY

We are pleased to offer suggestions on the use of our various products either by way of printed matter or through direct contact with our sales/application engineering staff. However, since we have no control over the use of our products once they are shipped, NO WARRANTY WHETHER OF MERCHANTABILITY, FITNESS FOR PURPOSE, OR OTHERWISE is made beyond the repair, replacement, or refund of purchase price at the sole discretion of Texmate. Users shall determine the suitability of the product for the intended application before using, and the users assume all risk and liability whatsoever in connection therewith, regardless of any of our suggestions or statements as to application or construction. In no event shall Texmate's liability, in law or otherwise, be in excess of the purchase price of the product.

Texmate cannot assume responsibility for any circuitry described. No circuit patent or software licenses are implied. Texmate reserves the right to change circuitry, operating software, specifications, and prices without notice at any time.



1934 Kellogg Ave., Carlsbad, CA 92008
Tel: 1-760-598-9899 • 1-800-TEXMATE • Email: orders@texmate.com

PC-45X Technical Manual Copyright © 2023 Texmate Inc. All rights reserved. Published by: Texmate Inc. USA. Information in this Technical Manual is subject to change without notice due to correction or enhancement. The information described in this manual is proprietary to Texmate, Inc. and may not be copied, reproduced or transmitted, in whole or in part, in connection with the design, manufacture, or sale of apparatus, device or private label product without the express written consent of Texmate, Inc.

Copyright © 2023 Texmate Inc. All Right Reserved.